

# Datasheet

- Measuring System in machine and plant construction
- Combined with analog data encoders; liner potentiometer etc.
- Encoder input configurable for resistance, current or Voltage
- 2 switching outputs
- Extremely reliable
- Accessories: Casing, brackets etc.



## Mechanical Data

Display	LED, 6-digits
Digits High	ca. 14 mm
Dimensions	48 x 96 x 75 mm (H x B x T)
Resolution	up to 15 Bit, Type: Delta-Sigma (ca. 4 measuring/sec.)
Measuring Range	-99.999 to +999.999
Measures	
Voltage	0 to 10 V
Current	0 to 20 mA or 4 to 20 mA
Resistance	1 k $\Omega$ to 100 k $\Omega$
0 ... 1 V or 0 ... 5 V, due to the resolution possible. For 4 ... 20 mA is at currents <3.5 mA "I ERROR". (Current) 82 $\Omega$ load to ground	

## Electrical Data

Power Supply	10 - 30 VDC or 230 VAC ( $\pm 10\%$ )
Encoder Supply	Ca. 24 VDC (max. 100 mA; analog)
PRESET-value	configurable
Counting Frequency	to 100 KHz
Output	2x Transistorausgang O.C. -> Masseschaltend, max. 30 VDC, max. 100 mA
Input	Masseschaltend; Einfrierfunktion
Balance	TEACH IN
Interface	RS 485 (optional)
IP-Rating	IP4x to IP5x, front IP6x seal (optional)

# Datasheet

## Pin Assignment

No.	Function	Comment
1	Encoder Supply +24 VDC	Max. 100 mA
2	Potentiometer-Supply +1,8 VDC	Potentiometer upper stop
3	Voltage Input	0 to 10 V
4	Current Input	0 to 20 mA
5	Potentiometer Grinder	Grinder
6	Sensor Ground	GND
7	Digital Input	Freeze function, low active
8	Ground Digital I/O	GND
9	Output 1	Max. 30 V, 100 mA (open collector, Ground)
10	Output 2	
11	RS485 - DÜB	Interface RS485 (optional)
12	RS485 - DÜA	
13	GND	Protective Conductor
14	Power Supply (N)	optional 230 VAC
15	Power Supply	

## Connections

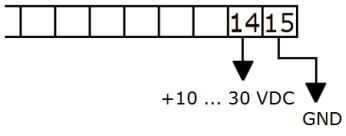
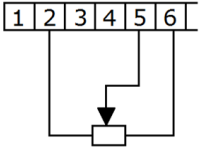
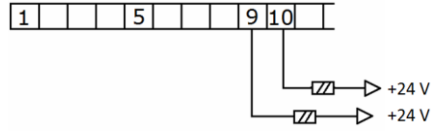
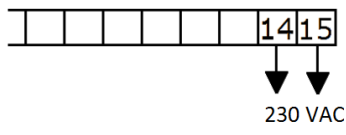
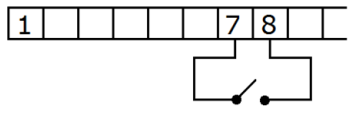
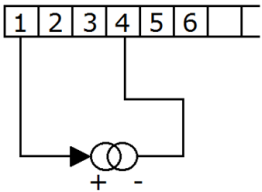
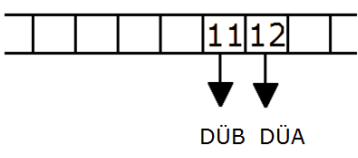
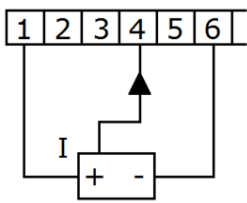
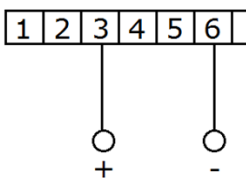
<b>Power Supply 24V</b>	<b>Potentiometer Input 1 kΩ ... 1 MΩ</b>	<b>2 Digital Inputs</b>
		
<b>230 V</b>	<b>Digital Input (Freeze Function)</b>	<b>Current 2-wire</b>
		
<b>RS485-Interface (optional)</b>	<b>Current 2-wire</b>	<b>Voltage Input 0 ... 10 V, 0 ... 1 V</b>
		

## Operation

Button	Arrow Left	Arrow right	SET
<b>Function</b>	RESET-Button	ABS-/REL-Button	PRESET-Button
<b>Programming Mode</b>	Change digit 1 to left	Increase digit by 1 or change parameters	15 sec. Press to enter the programming mode.
Start sequence: Display test (all segments), version display, measured value			

## Programming Mode

Menu	Name	Selectable Range	Default Values	Comment
<b>1 tYP</b>	Input Variable	Poti 0-20 0-10	Poti	Potentiometer 0 ... 20 mA 0 ... 10 V
<b>2 AP_1</b>	Value Adjustment Position 1	-99.999 to 999.999	0	Value that should be displayed at adjustment position 1
<b>3 AP_2</b>	Value Adjustment Position 2	-99.999 ... 999.999	10.000	Value that should be displayed at adjustment position 2
<b>4 SEt1</b>	Adjustment Point 1	---, SEt		Set adjustment point 1
<b>5 SEt2</b>	Adjustment Point 2	---, SEt		Set adjustment point 2
<b>6 dP</b>	Decimal Places	0, bis 0,0000	0,0	
<b>7 trE</b>	Change of ABS-/REL-Function	On; OFF	On	Rel-value is displayed by flashing decimal points
<b>8 oG</b>	Upper Limit Value	-99.999 to 99.999	0	If the limit values are equal the function is disabled
<b>9 uG</b>	Lower Limit Value	-99.999 to 99.999	0	
<b>10 bri</b>	Display brightness	1 to 5	5	1=darkest 2=highest
<b>11 Adr</b>	Device Address	001 to 255	001	
<b>12 Ctr</b>	Control			For internal use only

Example of a teach-in adjustment:

For example, it should be displayed -100.0 mm at the left potentiometer stop and 500.0 mm at the right potentiometer stop. Of course it can be chosen any points, it need not to be the potentiometer stop. The calibration points should be apart from each other as far as possible (higher accuracy).

- Put AP2 with potentiometer (e.g., 10K) into operation and change to programming menu.
- Set "Potentiometer" for type.
- Set the value "-100.0" at menu item "2 AP\_1".
- Set the value "500.0" at menu item "3 AP\_2".
- Turn potentiometer (sensor) to the left stop, change "4 SEt1" into "SEt" in the menu and confirm with the right SET- button.
- Turn potentiometer (sensor) to the right stop, change "5 SEt2" into "SEt" in the menu and confirm with the right SET- button.
- Set value "0.0" in menu item "5 dP".

# Datasheet

## Ordering Example

**Type** AP2 - 24 - 485

### Power Supply

**24** = 10 - 28 VDC  
**230** = 230 VAC

### Interface

**485** = RS485  
**0** = no