

Datasheet

Our modular system for a complete and flexible solution. The screw jack **MAR60** gear allows rotations to be converted into linear adjustment.

Features at a glance

- Screw jack for lifting and actuation systems
- For converting rotations into linear adjustment
- For motorized or manually adjustable rotary movements
- Trapezoidal threaded spindle in stainless steel (AISI 304), **TPN Ø 25 - 5 mm pitch**
- Housing in anodised aluminium, bevel gear and shaft in steel, surface-hardened
- High wear and fatigue resistance
- Long-lasting lubrication for maintenance-free operation
- Standard stroke lengths of the threaded spindle in mm: **100 - 200 - 300 - 400 - 650 - 700 - 1,000**
- Can be used individually or combined with flexible shafts, couplings, and gearboxes



Optional available on request:

- Version supplied complete with flange and extension shaft; compatible for mounting a spindle position indicator **OP7** or **EP7** for manual adjustment and direct reading of a measured value (see dimensions MAR60 FL-OP7/EP7)
- Lower protective cover made of stainless steel (AISI 303), upper protective cover with a spiral spring made of stainless steel (AISI 301) **for lengths up to 650 mm stroke.**

Technical characteristics

Rotation direction	Clockwise (clockwise rotation)
Axial load	200 kg on input shaft
Axial load	1,500 kg (500 kg with side bearing)
Screw load	<u>Avoid radial or side loads</u>
Revolution	max. 1,500 rpm
Backlash	0,75° up to 1.5° max.
Dimensions	
Spindle	TPN Ø 25 - 5 mm pitch
Stroke length	100 - 200 - 300 - 400 - 650 - 700 - 1,000 mm
Material	
Spindle	Stainless steel (AISI 304)
Housing	Aluminium, black anodised
Bevel gearbox and shaft	Steel, surface-hardened
Upper protective cover	Spiral spring Stainless steel (AISI 301)
Lower protective cover	Stainless steel (AISI 303)
Weight housing / Spindle	1.5 kg / 1.5 kg
Transmission ratio	1:1 - 1:2 - 1:4 - 1:7,5 - 1:10 - 1:15 - 1:20 - 1:30 - 1:40
Input torque	see performance table
Output torque	10 Nm
Operating temperature	-20 ... +80 °C
Life	10,000 h
Lubrication	SANEG LX EP 2 < 200 min-1 (grease) Castrol Optigear 1,100/100 > 200 min-1 (Oil)



Datasheet



Installation

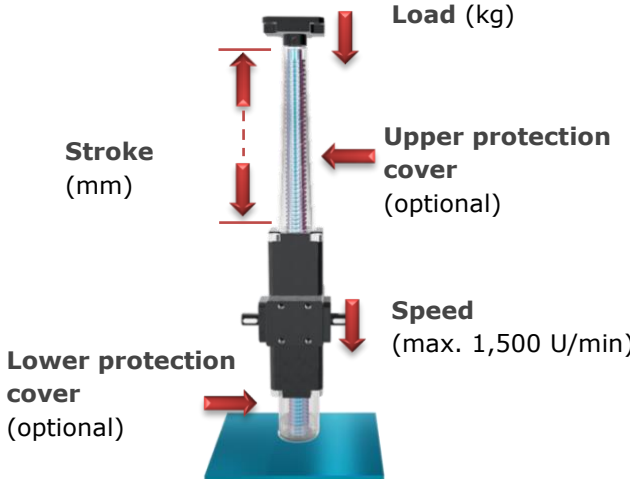

The main cause of breakage on the trapezoidal threaded spindle is radial loads caused by eccentricity. It is necessary to align the spindle and mounting surface of the gearbox orthogonally.

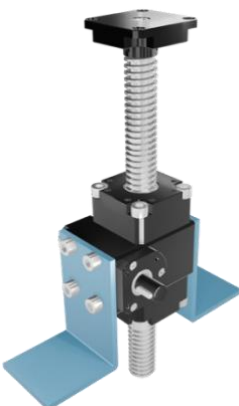
When mounting multiple screw jacks (also connected by shafts), it is essential that the couplings are perfectly aligned to distribute the load evenly. In this case, the use of flexible couplings is recommended to compensate for misalignments.

Sizing verification	Support and mounting
<p> Load (kg) – Mass on screw jack Speed (rpm) – Required max. 1,500 rpm Stroke (mm) – Useful linear travel Protection (opt.) – Screw shielding </p> 	<p>The unit must be firmly secured to the machine structure using a flat, rigid base (supports not included in the supply).</p> <div style="display: flex; justify-content: space-around;"> <div data-bbox="837 817 1093 1406"> <p>Bottom support</p>  <p>Plate/bracket under housing for optimal mounting</p> </div> <div data-bbox="1157 817 1412 1406"> <p>Lateral support</p>  <p>The side support allows a max. load of 500 kg</p> </div> </div>

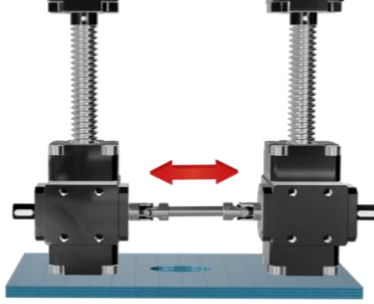
Installation		
 <p>Avoid radial/lateral loads on threaded bar, main cause of failure.</p>	 <p>Threaded bar and reducer plane orthogonal; ensure load/bar coaxial, avoid eccentricity.</p>	 <p>Multiple screw jacks: terminals aligned for uniform load; use couplings to compensate misalignments.</p>

Datasheet

Sizing verification

- Load (kg) = the force which is applied to the threaded spindle of the screw jack.
- Linear speed (mm/s) = the desired linear speed of load handling; it is recommended to limit the input rotatory speed to a maximum of 1,500 rpm.
- Stroke length (mm) = the linear distance the load must be moved, generally equal to the total length of the threaded spindle.
- Protective cover (optional on request) = to protect the threaded spindle in case of contamination, dust, foreign objects and/or oscillating installation and movements.
- Torque (Nm) = torque required to the load handling.

Dimensions

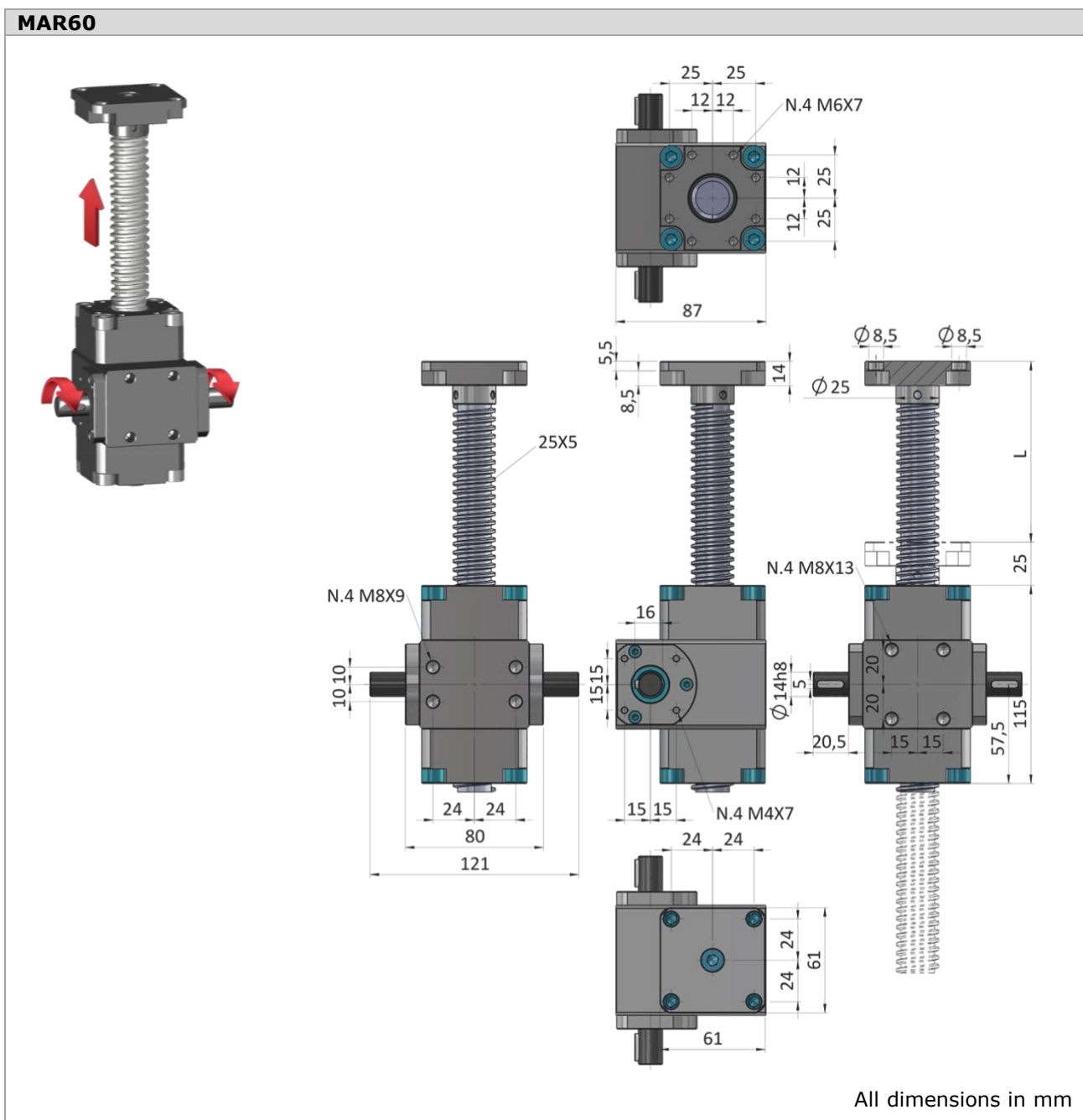

Datasheet

MAR60 FL-OP7 / EP7

Complete with fixing flange and extension shaft for display with OP7 digital or EP7 programmable indicator

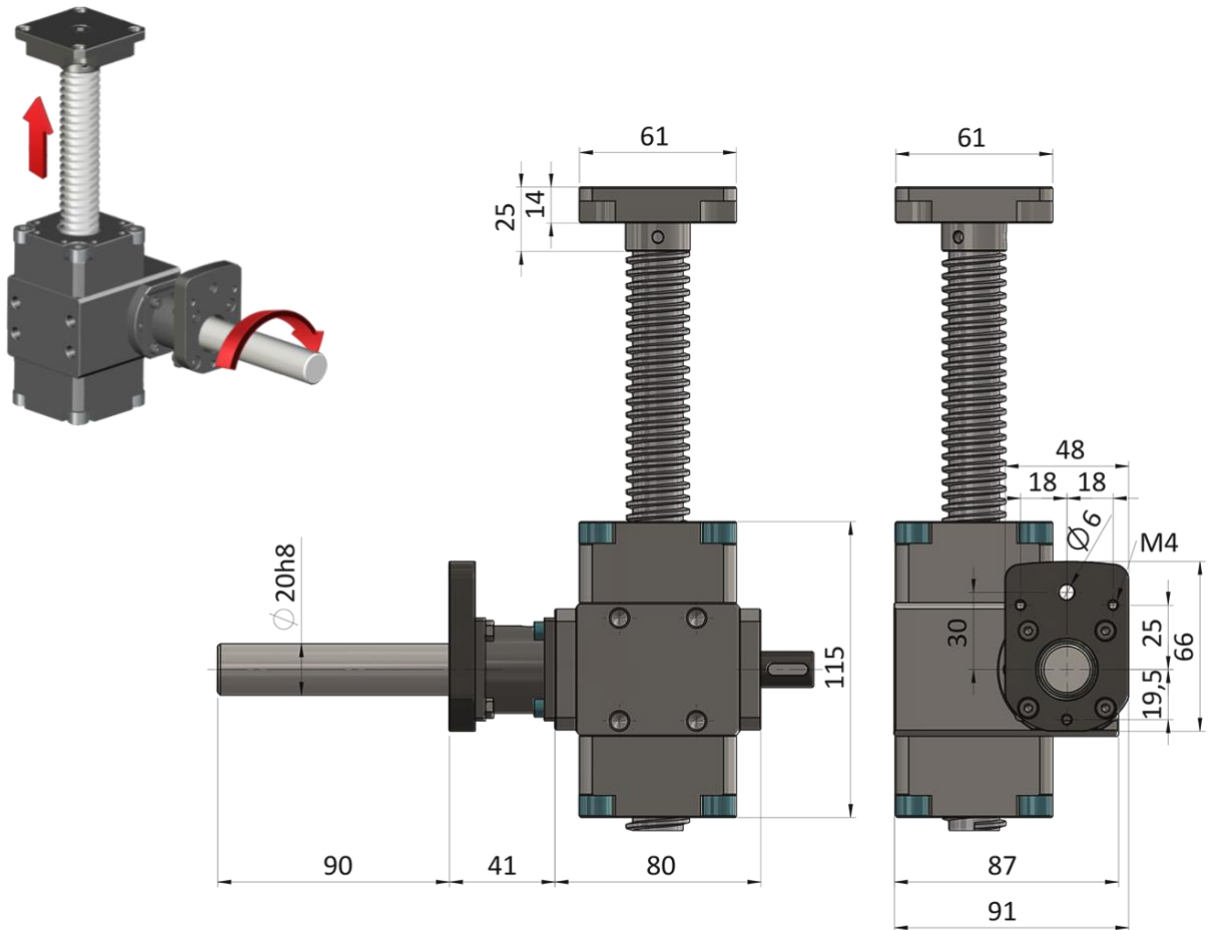

All dimensions in mm

Datasheet

MAR60-PROT

With rigid protection and spiral spring

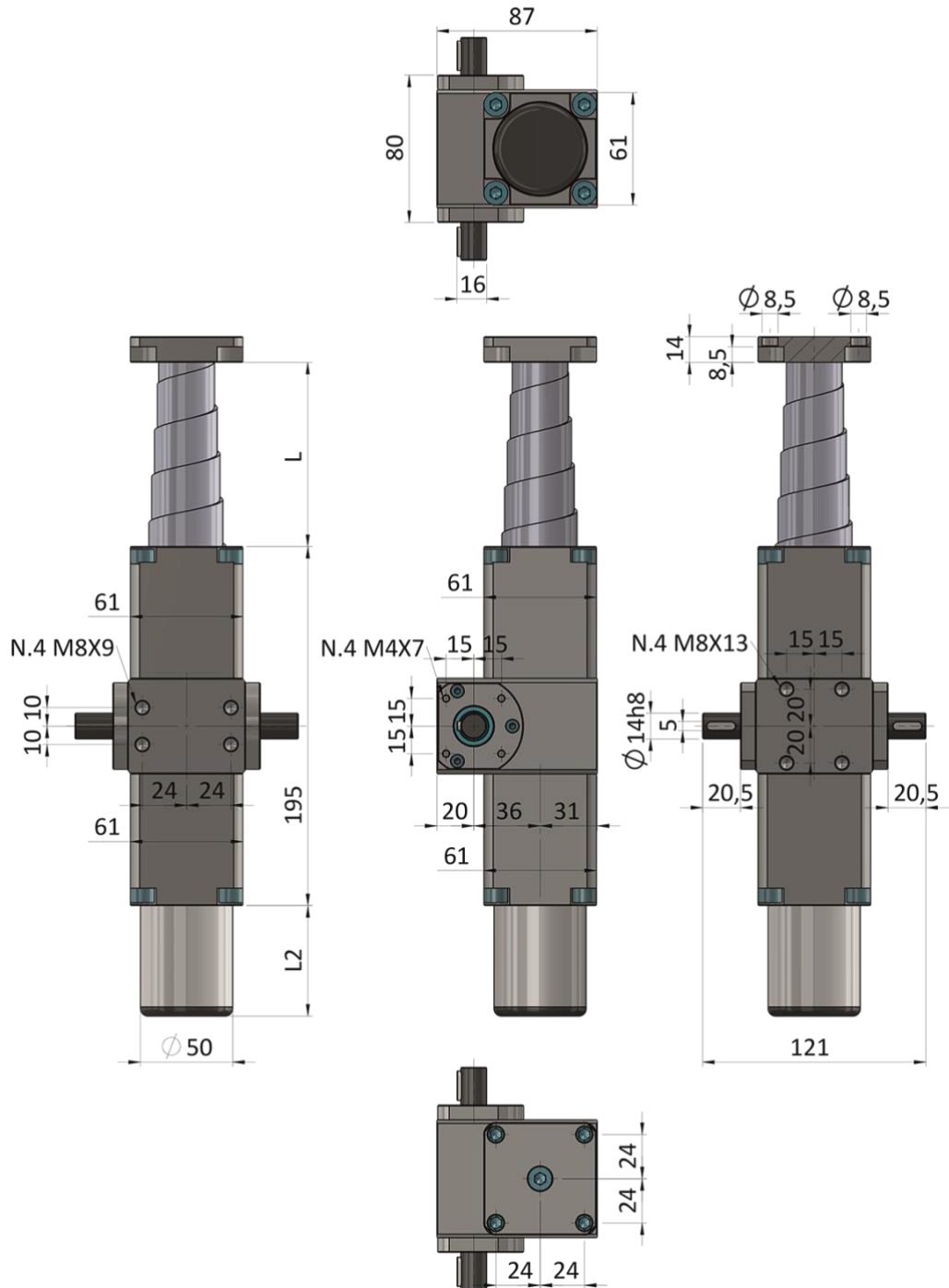

All dimensions in mm

Datasheet

MAR60 FL-OP7/EP7

Complete with mounting flange and extension shaft; compatible for mounting a spindle position indicator OP7 or programmable indicator EP7, for manual setting and direct reading of a measured value

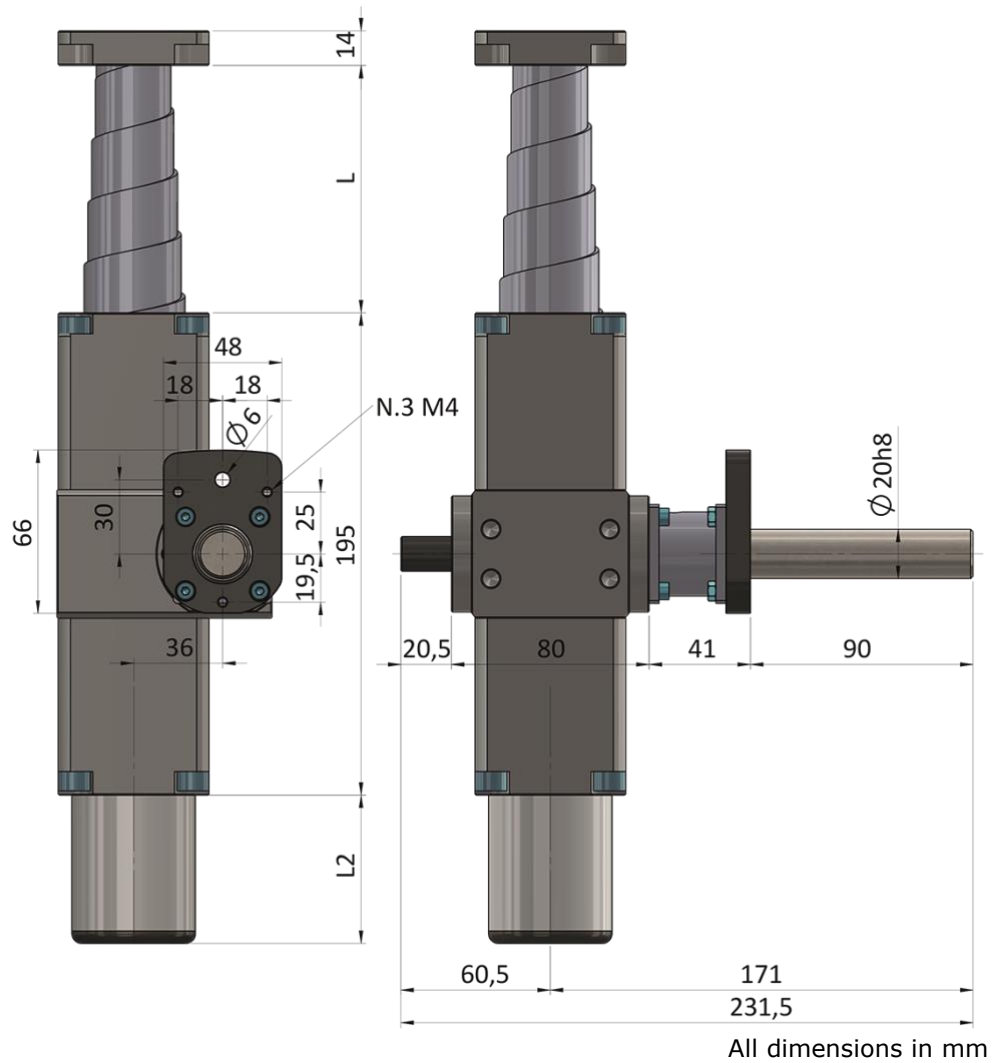
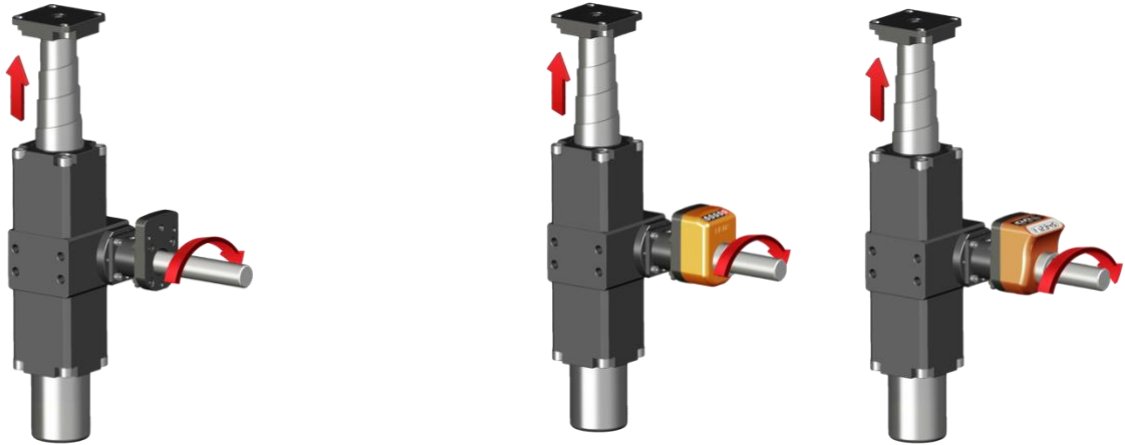

Datasheet

Performance table

Tab. 1	= Handling of loads according to the input torque
Tab. 2	= Handling of loads according to the trapezoidal spindle (with guides)
Tab. 3	= Spindle travel speed according to input speed
i	= Gear ratio [/]
T	= Torque [Nm]
C	= Handling of loads [kg]
s	= Measuring path [mm]
ω	= Rotational speed [rpm]
v	= Traversing speed [mm/s]

i [/]	Tab.1		Tab. 2		Tab. 3	
	T [Nm]	C [kg]	s [mm]	C [kg] (T=27 Nm)	ω [rpm]	v [mm/s]
1/1	1	25,6	100	691,7	250	20,83
	3	76,9	200	691,7	500	41,67
	5	128,1	300	691,7	750	62,50
	10	256,2	500	691,7	1000	83,33
	15	384,3	700	691,7	1250	104,17
	20	512,4	800	648,2	1500	125,00
	25	640,5	900	512,1		
	27	691,7	1000	414,8		
1/5	T [Nm]	C [kg]	s [mm]	C [kg] (T=8 Nm)	ω [rpm]	v [mm/s]
	1	128,1	100	1024,8	250	4,17
	2	256,2	200	1024,8	500	8,33
	3	384,3	300	1024,8	750	12,50
	4	512,4	500	1024,8	1000	16,67
	5	640,5	700	846,6	1250	20,83
	6	768,6	800	648,2	1500	25,00
	7	896,7	900	512,1		
8	1024,8	1000	414,8			
1/12,5	T [Nm]	C [kg]	s [mm]	C [kg] (T=6 Nm)	ω [rpm]	v [mm/s]
	0,8	205,0	100	1537,2	250	1,67
	1,6	409,9	200	1537,2	500	3,33
	2,4	614,9	300	1537,2	750	5,00
	3,2	819,8	500	1537,2	1000	6,67
	4	1024,8	700	846,6	1250	8,33
	4,8	1229,7	800	648,2	1500	10,00
	5,6	1434,7	900	512,1		
6	1537,2	1000	414,8			
1/25	T [Nm]	C [kg]	s [mm]	C [kg] (T=4 Nm)	ω [rpm]	v [mm/s]
	0,5	192,1	100	1537,2	250	0,83
	1	384,3	200	1537,2	500	1,67
	1,5	576,4	300	1537,2	750	2,50
	2	768,6	500	1537,2	1000	3,33
	2,5	960,7	700	846,6	1250	4,17
	3	1152,9	800	648,2	1500	5,00
	3,5	1345,0	900	512,1		
4	1537,2	1000	414,8			

Datasheet

Order example

Typ	MAR60	-	1:1	-	200	-		-		-	
MAR60											
Transmission ratios											
1:1 - 1:2 - 1:4 - 1:7,5 - 1:10 - 1:15 - 1:20 - 1:30 - 1:40											
Stroke length (mm)											
100 - 200 - 300 - 400 - 650 - 700 - 1,000											
Model - Lower protection cover (optional)											
Not specified	=	without protective cover (standard)									
PROT-INF-IN	=	with protective tube, stainless steel (AISI 303)									
Model - Upper protection cover Spiral spring (optional)											
Not specified	=	without protective cover (standard)									
PROT-SUP-IN	=	with protective tube, stainless steel (AISI 301)									
Coupling flange (optional)											
Not specified	=	without a coupling flange (standard)									
FL-OP7/EP7	=	for Spindle position indicator									
Position indicator (optional) please order separately											
Not specified	=	without a Spindle position indicator (standard)									
OP7	=	Spindle position indicator OP7									
EP7	=	Spindle position indicator EP7									









Our **MAR60** spindle position indicator are available in combination with the spindle position indicator **OP7/EP7**. Please order spindle position indicator separately. Further information on our spindle position indicators can be found on the corresponding data sheet.

Other versions that cannot be generated from the order code may be available as special versions on request.

Datasheet

Accessory

<p>Hand wheels</p> 	<p>Reversible handles</p> 	<p>Bearing brackets</p> 	<p>Flanges</p> 
<p>Cardan joints</p> 	<p>Coupling shafts</p> 	<p>Clamping flanges</p> 	

System components

<p>Mechanical/digital position indicator</p> 	<p>Programmable position indicator</p> 	<p>Angular gearboxes</p> 	<p>Axle modules</p> 
--	--	---	---

Datasheet

Combination / application options

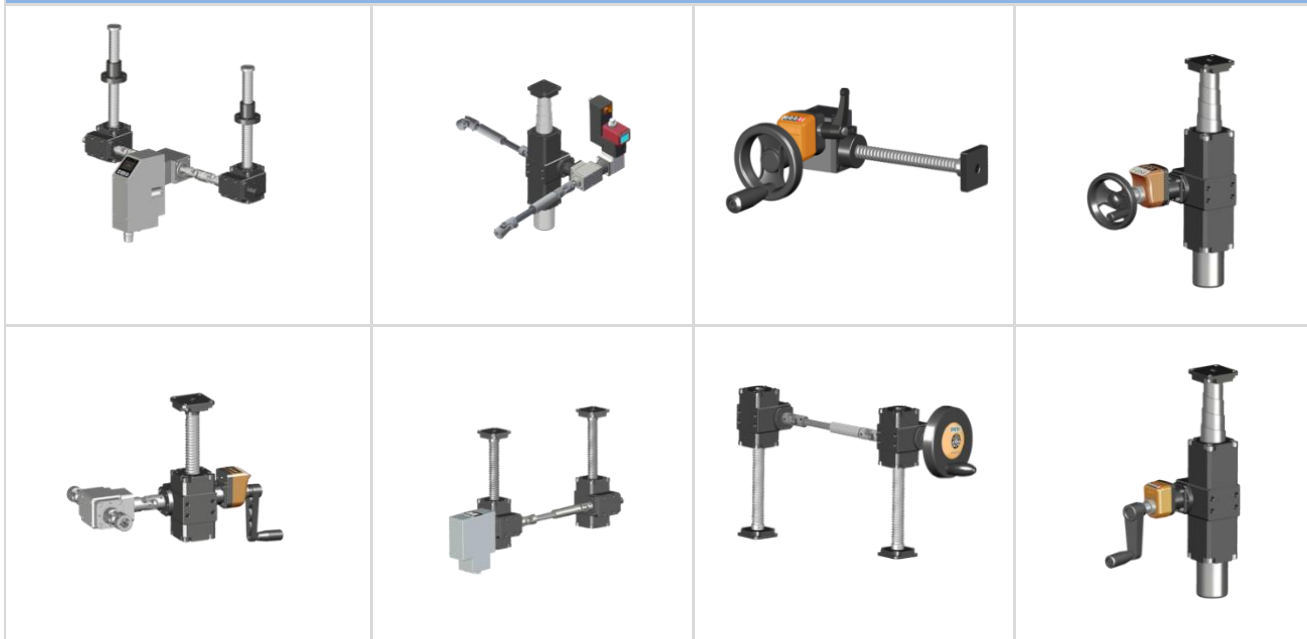

You can find more information on our homepage www.willtec.de

Manufacturer: **FIAMA** since 1913

The manufacturer reserves the right to make changes to the products that it deems necessary for their improvement without prior notice.