



2REX-A-NA-SSI with cable

- Shaft Encoder – Ø 68 mm
- Shaft: Ø10 mm
- SSI Interface
- Singleturn or Multiturn
- Non-removable end cap – delivered with cable
- ATEX, IECEx, EAC Ex certified

Electrical Specifications

Encoder Type:	Absolute Multiturn
Singleturn Resolution:	13 bits (8192) steps per revolution
Number of Revolutions:	12 bits (4096) revolutions 16 bits (65536) revolutions 20 bits (1048576) revolutions 24 bits (16777216) revolutions
Supply Voltage:	5 VDC ±5% or 9-30 VDC
Typical Current Consumption:	30 mA @ Vsup = 5V 25 mA @ Vsup = 10V 15 mA @ Vsup = 24V
Accuracy:	± 0,35°
Interface:	SSI (Synchronous Serial Interface)
Output Code:	Binary or Gray
Electrical Interface:	Differential (RS422)
Clock Frequency:	100 kHz to 2 MHz
Counting Direction:	Increasing clockwise or increasing counter clockwise seen from shaft end of encoder
Electrical Protection:	Reverse polarity and output short circuit protected
Noise Immunity:	EN61000-6-2: 2005 (industrial environments) Electromagnetic compatibility (EMC) EN 61000-6-3: 2007 (residential, commercial, and light-industrial environments) for Electromagnetic compatibility (EMC)

Mechanical Specifications

Material:	Housing: Aluminum Cap: Aluminum Shaft: Stainless Steel (AISI 303)
Weight:	Encoder: Approx. 540 gr (19 oz) Cable: 50 gr / meter (1.76 oz / meter)
Bearing Life:	> 1.9 x 10 ¹⁰ revolutions at rated load
Shaft Speed:	3000 rpm continuous (max.) IP 67
Starting Torque:	< 0.1 Nm (14.16 oz-in) at 25° C IP 67
Mass Moment of Inertia:	50 gcm ² (7.08 x 10 ⁻⁴ oz-in-sec ²)
Shaft Loads:	Axial 50 N (11.25 lbs) max. Radial 100 N (22.50 lbs) max.

Environmental Specifications

Operating Temp.:	-40° to +70° C
Storage Temp.:	-40° to +85° C
Shock:	100 G / 11 ms
Vibration:	10 G / 10-2000 Hz
Bump:	10 G / 16 ms (1000 x 3 axis)
Humidity:	98 % RH without condensation
Enclosure Rating:	IP 64 / Nema 4 (approx.) option IP 65 / Nema 4 (approx.) option IP 66 / Nema 6 (approx.) option IP 67 / Nema 6 (approx.) option

Connection Options

Cable:	MUD resistant (NEK 606) & halogen free, shielded, OD Ø6.6 +/- 0.2 mm 4x2x0.14 mm ² , 26 AWG, 4 twisted pairs; <i>See Table 1</i>
---------------	--

Certifications

ATEX:	Certificate No.: ITS 09 ATEX 16847X II 2 G Ex db IIC T5 II 2 D Ex tb IIIC T100°C Db -40°C<Tamb<+70°C
IECEX:	Certificate No.: IECEX ITS 10.0015X Ex db IIC T5 Gb Ex tb IIIC T100°C Db -40°C < Tamb < +70°C
EAC Ex:	НАННО «ЦСВЭ» No. EAЭC RU C-DK.AA87.B.00266/19 1Ex db IIC T5 Gb X, Ex tb IIIC T100°C Db X, -40°C<T.amb<+70°C

SSI Interface Timing

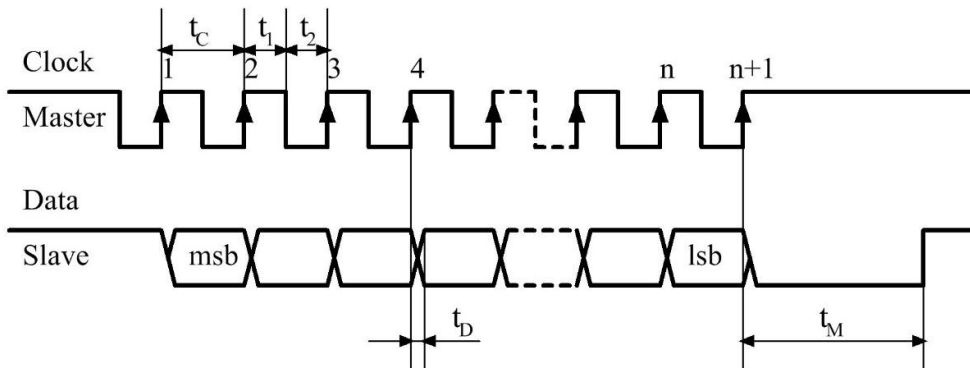

msb = Most Significant Bit

lsb = Least Significant Bit

n = Total Number of Bits

t_c = Clock Period = 0.5 to 10 μ Sec (100kHz to 2 MHz)

t_1 = Clock High = 50% \pm 15% of Clock Period

t_2 = Clock Low = 50% \pm 15% of Clock Period

t_D = Clock to Data Valid = Max. 100 nSec

t_M = Monoflop Time = 20 \pm 3 μ Sec

Implementation

During the initial set-up and installation of the encoder, it is possible to set the direction of rotation and preset the encoder to zero.

Setting of Direction.

The connection designated “Direction” is used to set the direction of rotation. Notice, that the encoder must not be powered when the direction of rotation is set/changed. Notice also, that the encoder will change its position value when the direction of rotation is changed. Direction of rotation is viewed on the shaft end of the encoder.

Voltage Level on Input	Function
High: V_{sup} or $V_{sup}/2 \leq V_{in} \leq V_{sup}$	Encoder Increasing on Counter Clockwise Rotation
Low: Input not connected or $0V \leq V_{in} \leq V_{sup}/2$	Encoder Increasing on Clockwise Rotation

Preset to Zero

The connection designated “Preset” is used to preset the encoder to zero. Notice, that the encoder must be powered when it is preset to zero.

Voltage Level on Input	Function
High: V_{sup} or $V_{sup}/2 \leq V_{in} \leq V_{sup}$	Encoder Value is set to Zero
Low: Input not connected or $0V \leq V_{in} \leq V_{sup}/2$	Inactive

The encoder will be held at zero as long as the line is high, even though the shaft is turned. The line must be high for at least 100 mSec. for the preset to take effect. The new zero point will be stored permanently in the encoder.

Face Mounts

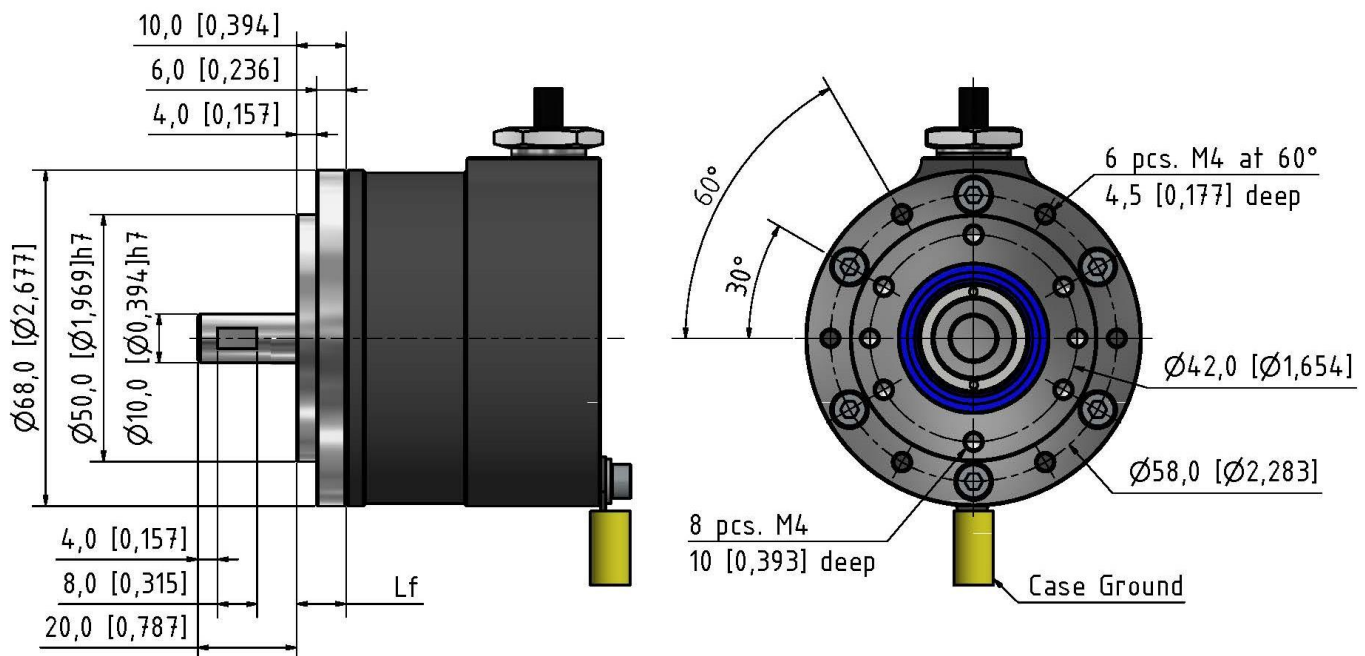

Face Mount A

mm (inches)

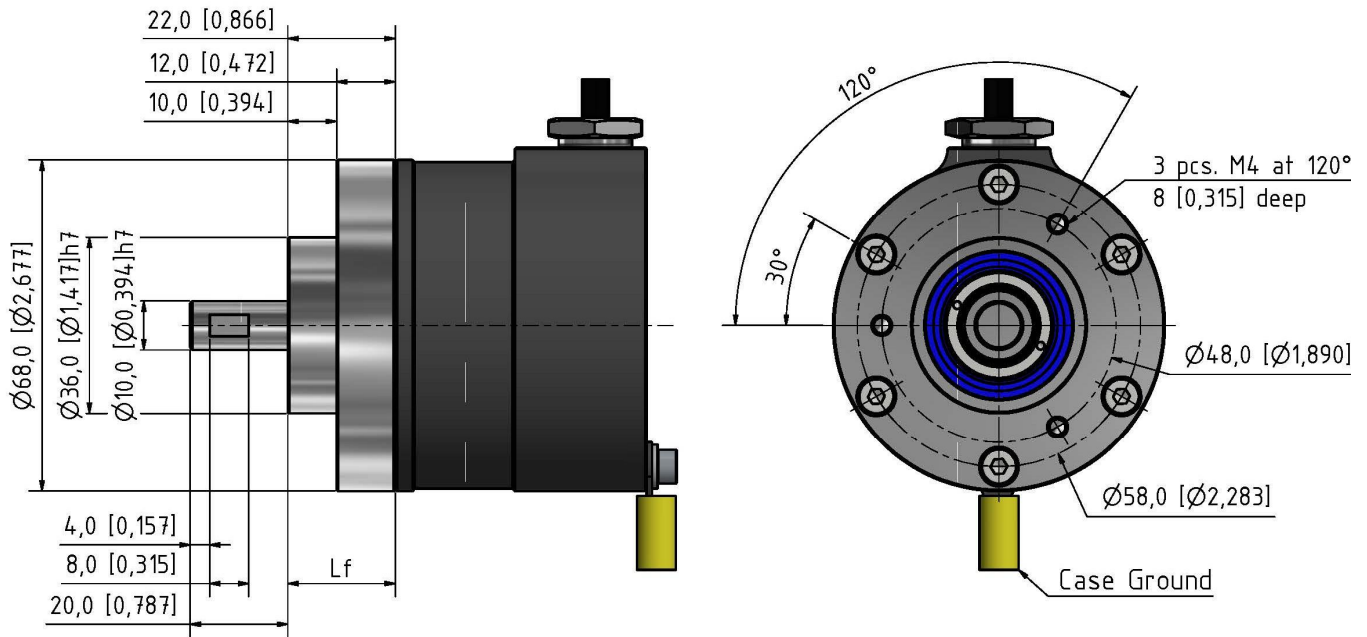

Face Mount K

mm (inches)

Caps with Cable

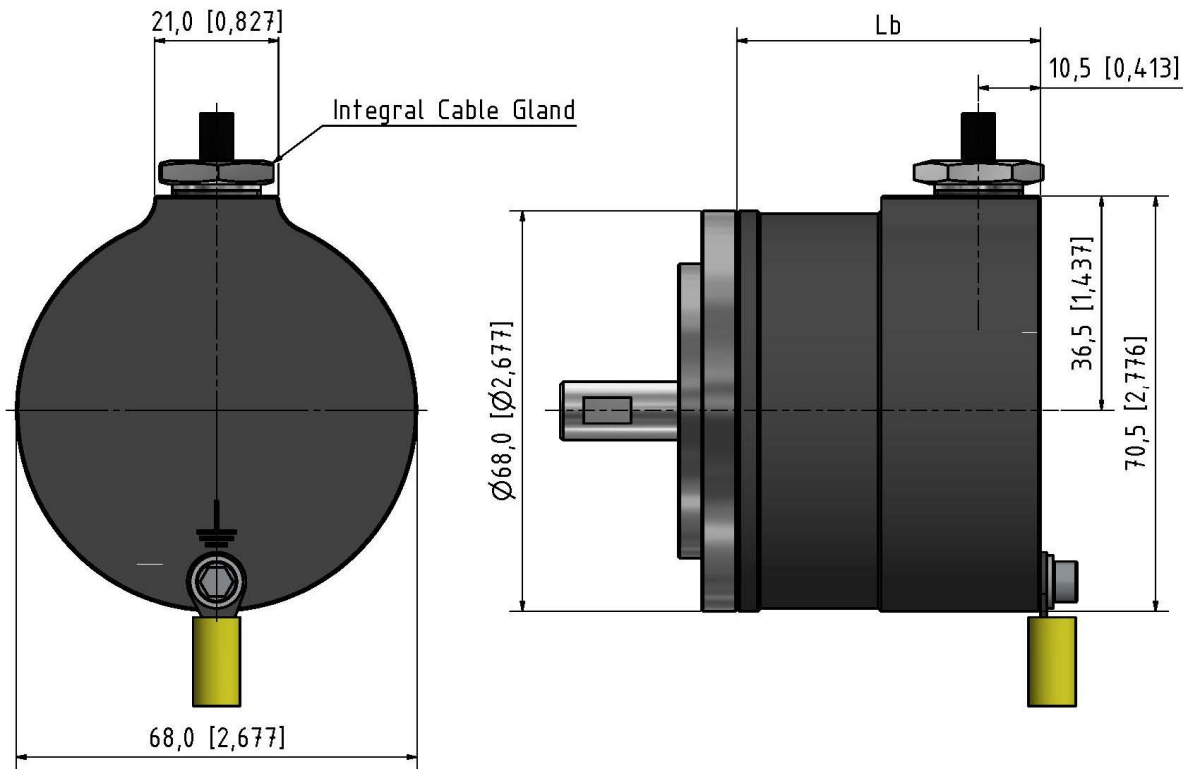

Side Standard Cable Gland Cap (SS)

mm (inches)

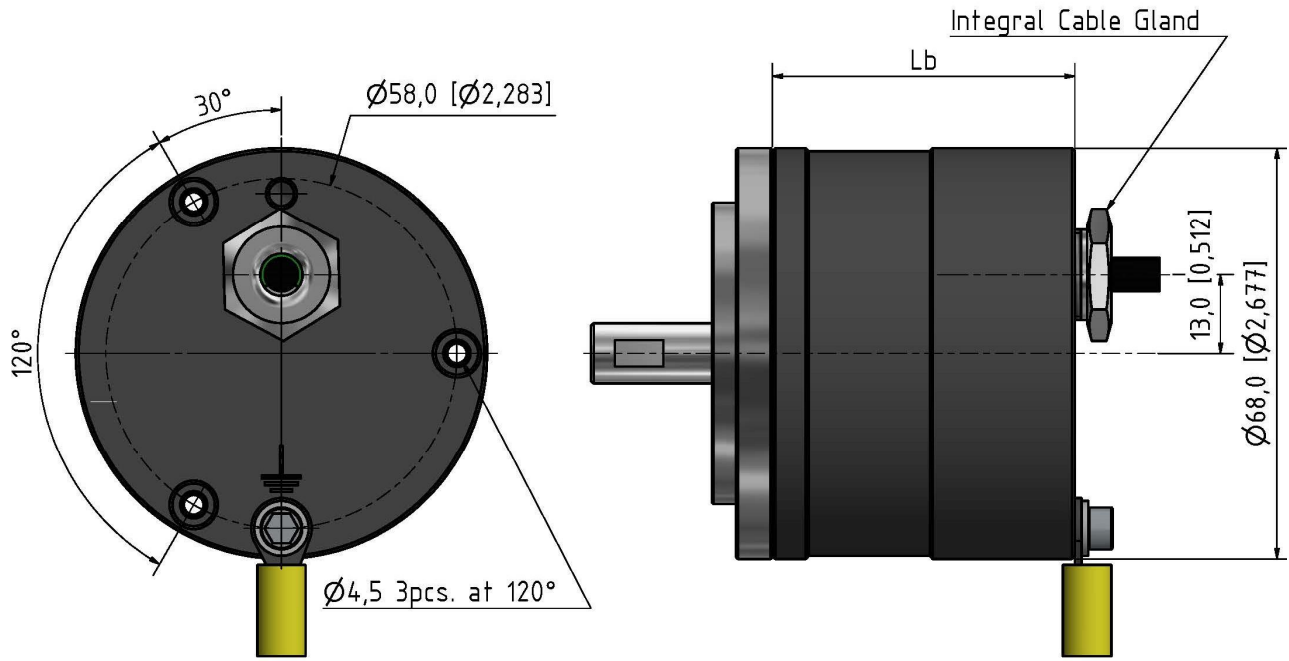

Back Standard Cable Gland Cap (BS)

mm (inches)

Encoder Length

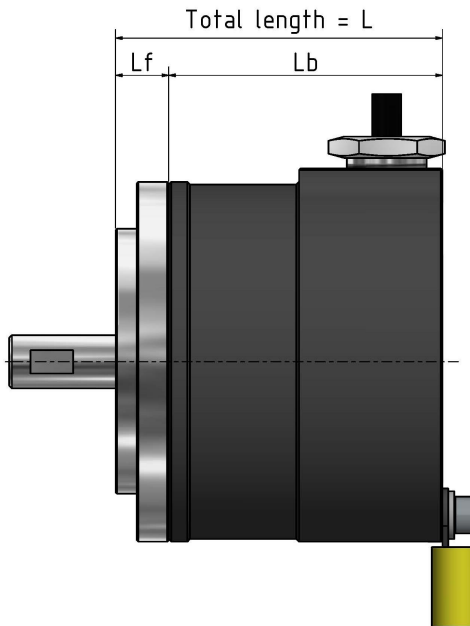

Total Encoder Length $L = L_b + L_f$

Cap	Face mount A	Face mount K
SS	61,5 mm (2,42 in)	73,5 mm (2,89 in)
BS	60,0 mm (2,36 in)	72,0 mm (2,83 in)

Cap + Face Mount = Total Encoder Length

Table 1. Cable Output

Signal	Cable
	Differential Input/Output
	Wire Color
CLK+	Green
CLK-	Yellow
DO+	Gray
DO-	Pink
Direction	Red
Preset	Blue
Vsup	Brown
GND	White

Shield connected to case ground

GND = Circuit Ground

Shield connected to Case Ground

Cable: **MUD resistant (NEK 606) & halogen free, shielded**
 4x2x0.14 mm², 26 AWG, 4 twisted pairs, OD Ø6.6 +/- 0.2 mm;
 Yellow cable shoe: AWG 12-10

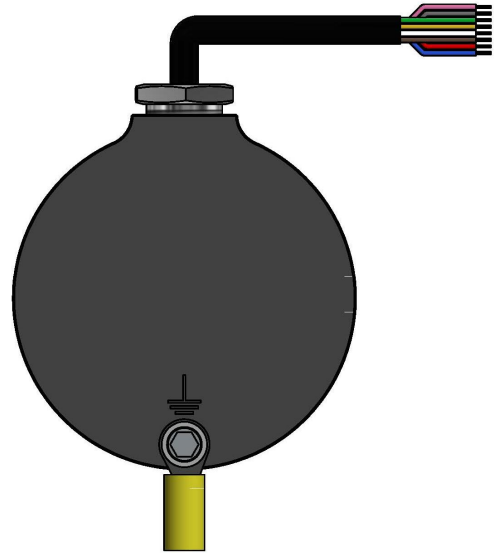

Ordering Code

Example: 2REX-A-NA-SSI – 1613 – AL – 9 – B – D – 10 – 20 – 67 – 25 – SS – A – 00

2REX-A-NA-SSI - - - - - - - - - - - - - -

1 2 3 4 5 6 7 8 9 10 11 12

1. Resolution

Singleturn
 Resolution 13 bits **0013**
Multiturn
 Revolutions 12 bits **1213**
 Revolutions 16 bits **1613**
 Revolutions 20 bits **2013**
 Revolutions 24 bits **2413**

2. Material

Aluminium..... **Al**

3. Supply Voltage

5 VDC..... **5**
 9-30 VDC..... **9**

4. Code

Binary **B**
 Gray **G**

5. Electrical Interface

Differential (RS422)..... **D**

6 & 7. Shaft diameter

10 mm x 20 mm (Flanges A, K)

6. 7.

10 x 20

8. IP Rating

IP 64 **64**
 IP 65 **65**
 IP 66 **66**
 IP 67 **67**

9. Cable Length

Standard cable is 1m..... **01**
 Specify length..... **XX**

10. Cable Takeout

Side (Standard)..... **SS**
 Back (Standard)..... **BS**

11. Flange

Flange A **A**
 Flange K..... **K**

12. Accessory

No accessory..... **00**