

# Datasheet

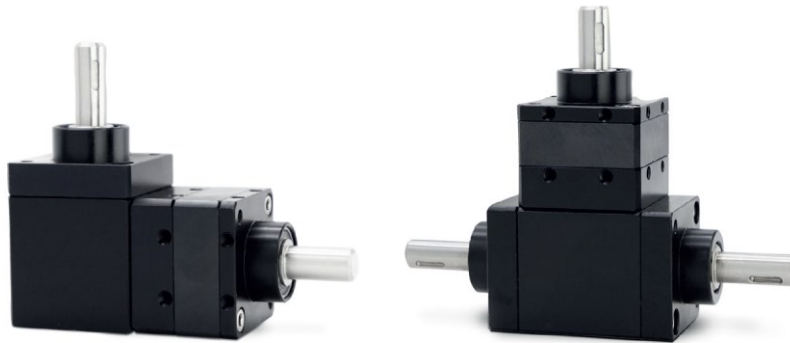

This model combines a planetary reducer with a 90° spiral bevel gearbox to create a compact, space-saving solution that provides both speed reduction and right-angle transmission of motion. An intelligent system for right-angle gear applications that offers a good compromise between precision, reliability, and performance.

## Features at a glance

- Many ratios available.
- Numerous installation options; mounting in any position and orientation; therefore this model is suitable for many applications.
- Low vibration and noise due to spiral gear.
- The aluminium and surface-treated steel housing ensures low weight and allows use even in rough environments.
- The design not only offers a high degree of flexibility in configuration, but also guarantees wide compatibility for immediate retrofits and countless integration possibilities.
- Various mounting possibilities with solid and hollow shafts, coupling flanges, visualisation with mechanical or electronic position indicator possible.

## Technical characteristics

Gear	Right-angle planetary reducer
Nominal output torque	12 Nm intermittent 5 Nm continuous
Axle load at input/output	Radial load 25 N Axial load 1 N
Gear backlash <sup>1)</sup>	max. 0,5°
Material	
Shafts	AISI 303 stainless steel
Housing	black anodised aluminium (standard)
Internal gear ring	AVP steel
Version	
A	with 2 shafts
B	with 3 shafts
C	with 3 shafts (with opposite rotation)
D	with 3 shafts (2 through hollow shafts)
Weight	
	535 g 1-stage, with 2 shafts (Version A)
	650 g 2-stage, with 2 shafts (Version A)
	765 g 3-stage, with 2 shafts (Version A)
	635 g 1-stage, with 3 shafts (Version B, C, D)
	750 g 2-stage, with 3 shafts (Version B, C, D)
	865 g 3-stage, with 3 shafts (Version B, C, D)
Operating temperature	-20° – +90° C
Lubrication	Grease <i>Gazprom Neft LX EP2</i> (at intermittent use) Oil <i>Castrol Optigear 110/100</i> (at continuous use)

# Datasheet

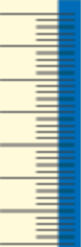

Input speed	6.000 rpm
Service life <sup>1)</sup>	10.000 hours
Protection degree	IP65

- 1) Combines a planetary reducer with a 90° spiral bevel gearbox.
- 2) Depends on the ambient conditions and the operating data of the drive system. A wide range of possible applications does not allow a generally valid statement about the service life.



For a correct selection of right-angle planetary reducers, see the following tables of technical and performance characteristics, as well as the corresponding versions with dimensions.

## Efficiency tables

Stages	Ratio	Efficiency
<b>1S</b>	3	81%
	4	81%
	5	81%
	10	81%
<b>2S</b>	15	73%
	20	73%
	25	73%
	30	73%
	40	73%
	50	73%
<b>3S</b>	75	66%
	100	66%
	125	66%
	150	66%
	200	66%
	250	66%

Input speed (rpm)	Output torque (Nm)	Input speed (rpm)	Output torque (Nm)
4000	3	4000	1,5
3000	4	3000	2
2000	5	2000	2,5
1000	6	1000	3
500	8	500	4
250	8	250	4
100	10	100	5
50	10	50	5
10	10	10	5
Grease (at intermittent use)		Oil (at continuous use)	

<sup>1)</sup> In this case, please contact our technical service.

RDE405\_DB\_2021-10-17\_EN

# Datasheet

## Versions and dimensions

### Version A V-V solid shaft-solid shaft

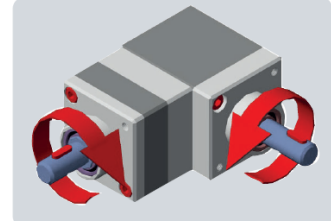
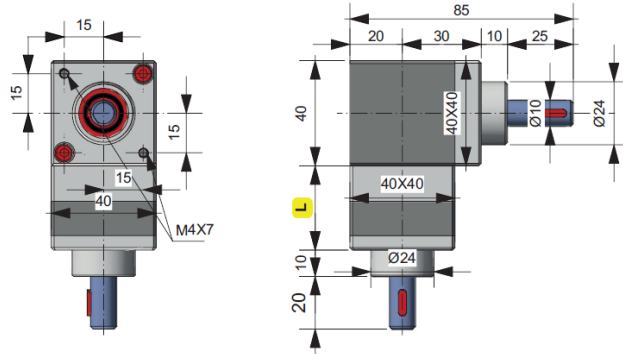

DIMENSIONS - ABMESSUNGEN			
	1 S	2 S	3 S
L	32	46,5	61

### Version B V-V-V solid shaft-solid shaft-solid shaft

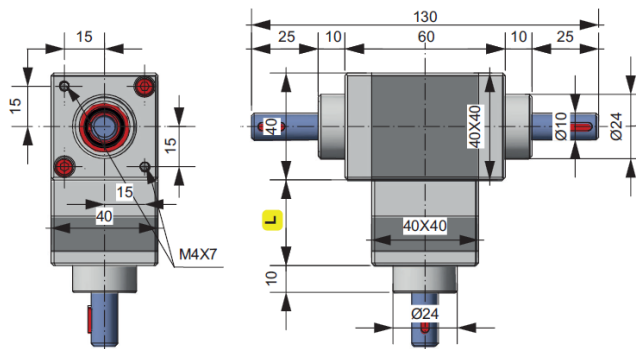

DIMENSIONS - ABMESSUNGEN			
	1 S	2 S	3 S
L	32	46,5	61

### Version C V-V-V solid shaft-solid shaft-solid shaft

(Opposite rotation)

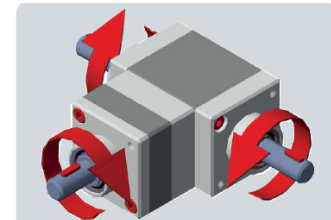
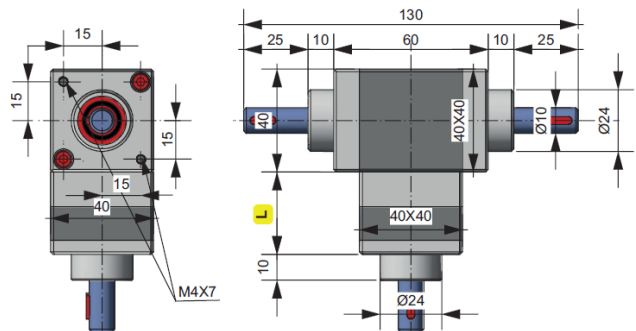

DIMENSIONS - ABMESSUNGEN			
	1 S	2 S	3 S
L	32	46,5	61

### Version D V-H-H solid shaft-hollow shaft-hollow shaft

(With through hollow shaft)

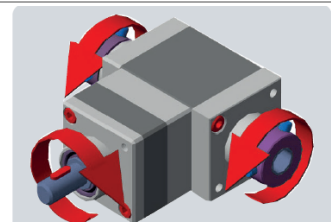
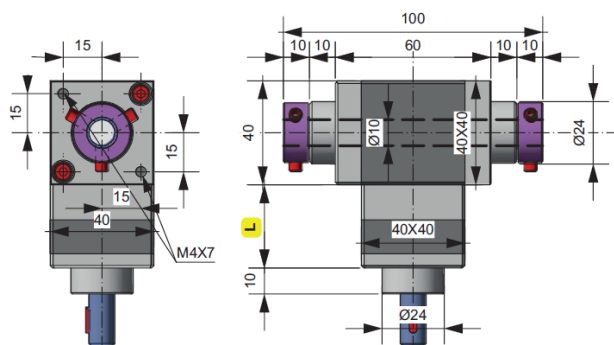

DIMENSIONS - ABMESSUNGEN			
	1 S	2 S	3 S
L	32	46,5	61

# Datasheet

## Combinations of available shaft couplings

Version **A, B, C, D** ; stages **1S, 2S, 3S** ; **V** solid shaft, **H** hollow shaft

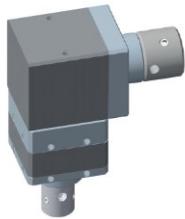
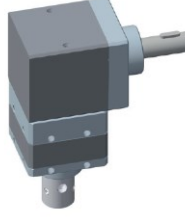
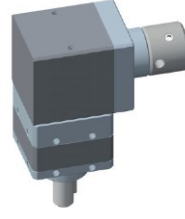
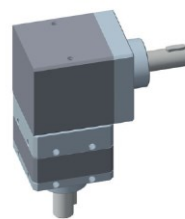
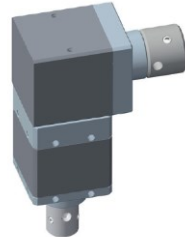
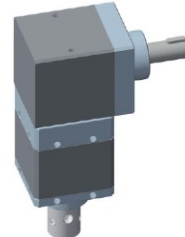
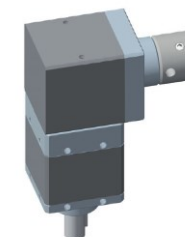
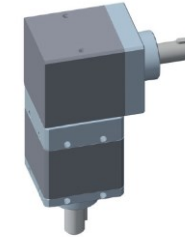
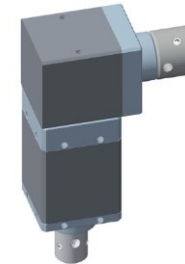
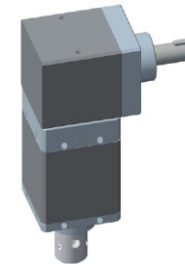
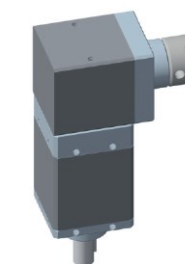
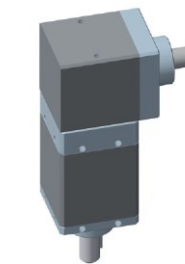
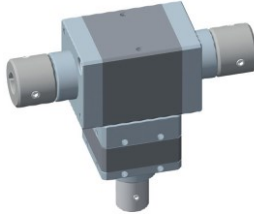
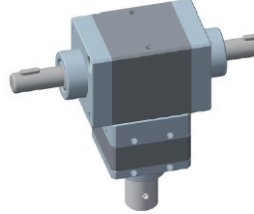
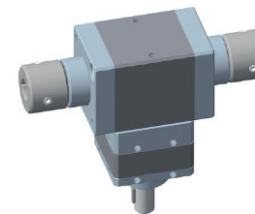
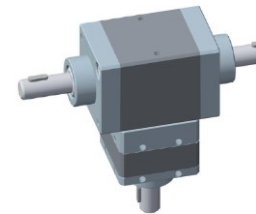
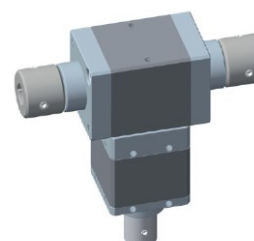
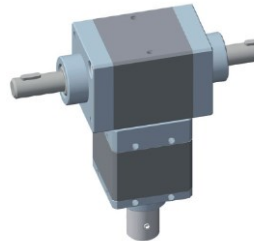
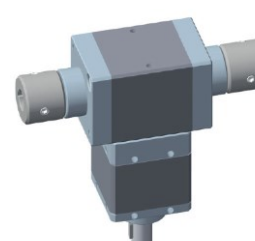
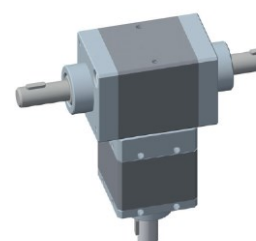

<b>A - 1S - H-H</b>	<b>A - 1S - H-V</b>	<b>A - 1S - V-H</b>	<b>A - 1S - V-V</b>
			
<b>A - 2S - H-H</b>	<b>A - 2S - H-V</b>	<b>A - 2S - V-H</b>	<b>A - 2S - V-V</b>
			
<b>A - 3S - H-H</b>	<b>A - 3S - H-V</b>	<b>A - 3S - V-H</b>	<b>A - 3S - V-V</b>
			
<b>B - 1S - H-H-H</b>	<b>B - 1S - H-V-V</b>	<b>B - 1S - V-H-H</b>	<b>B - 1S - V-V-V</b>
			
<b>B - 2S - H-H-H</b>	<b>B - 2S - H-V-V</b>	<b>B - 2S - V-H-H</b>	<b>B - 2S - V-V-V</b>
			

RDE405\_DB\_2021-10-17\_EN

# Datasheet

## Combinations of available shaft couplings (Continued)

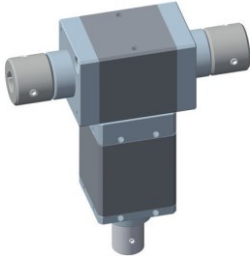
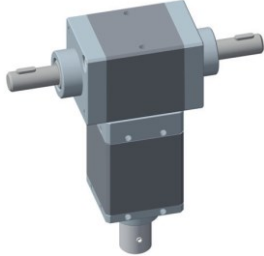
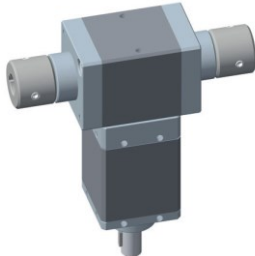
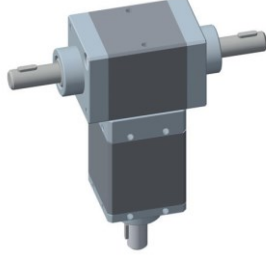
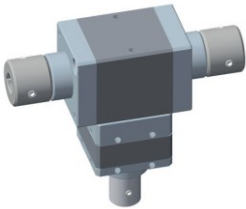
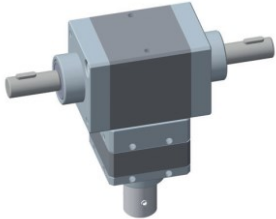
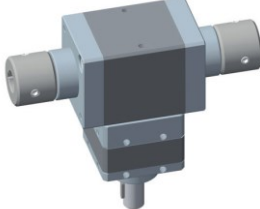
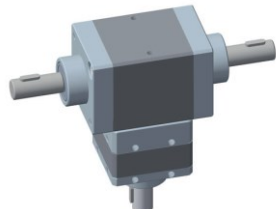
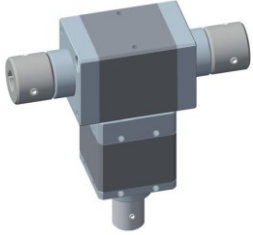
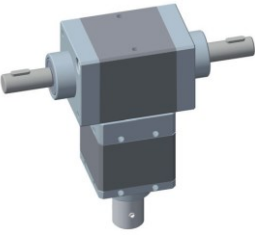
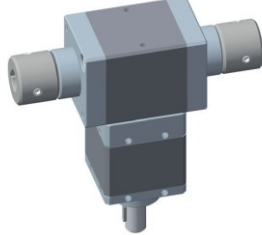
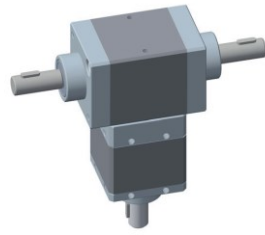
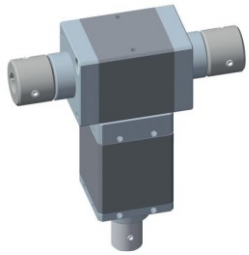
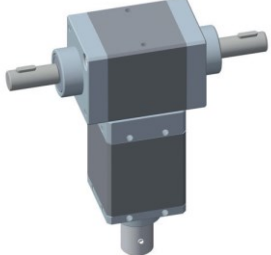
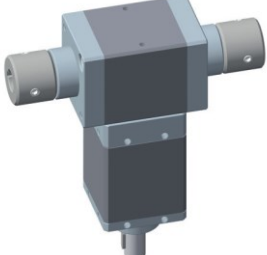
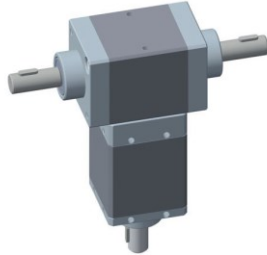
Version **A, B, C, D** ; stages **1S, 2S, 3S** ; **V** solid shaft, **H** hollow shaft

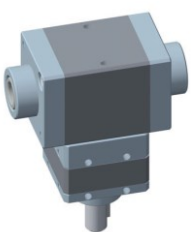
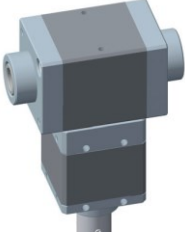
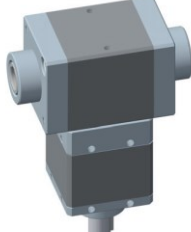
<b>B - 3S - H-H-H</b>	<b>B - 3S - H-V-V</b>	<b>B - 3S - V-H-H</b>	<b>B - 3S - V-V-V</b>
			
<b>C - 1S - H-H-H</b>	<b>C - 1S - H-V-V</b>	<b>C - 1S - V-H-H</b>	<b>C - 1S - V-V-V</b>
			
<b>C - 2S - H-H-H</b>	<b>C - 2S - H-V-V</b>	<b>C - 2S - V-H-H</b>	<b>C - 2S - V-V-V</b>
			
<b>C - 3S - H-H-H</b>	<b>C - 3S - H-V-V</b>	<b>C - 3S - V-H-H</b>	<b>C - 3S - V-V-V</b>
			
<b>D - 1S - H-H-H</b>	<b>D - 1S - V-H-H</b>	<b>D - 2S - H-H-H</b>	<b>D - 2S - V-H-H</b>
			

RDE405\_DB\_2021-10-17\_EN

# Datasheet

## Combinations of available shaft couplings (Continued)

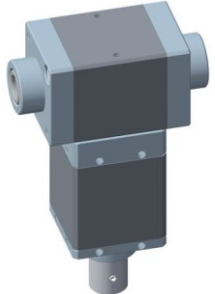
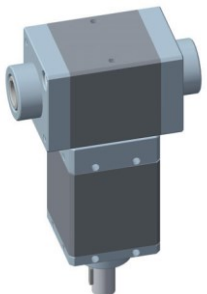
Version <b>A, B, C, D</b> ; stages <b>1S, 2S, 3S</b> ; <b>V</b> solid shaft, <b>H</b> hollow shaft			
<b>D - 3S - H-H-H</b>	<b>D - 3S - V-H-H</b>		
			

## Ratios

1-stage			2-stage					3-stage							
3	4	5	19	15	20	25	30	40	50	75	100	125	150	200	250

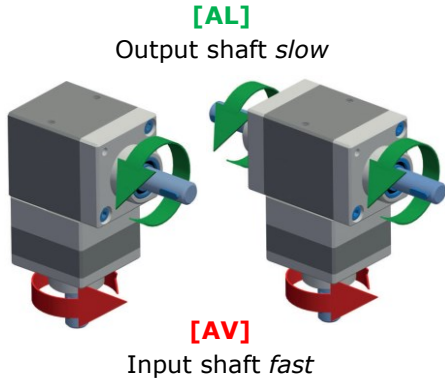
Gear ratios				
		1-stage	2-stage	3-stage
		<b>AV = 3 - AL = 1</b>	<b>AV = 15 - AL = 1</b>	<b>AV = 75 - AL = 1</b>
<b>AV = 4 - AL = 1</b>	<b>AV = 20 - AL = 1</b>	<b>AV = 100 - AL = 1</b>		
<b>AV = 5 - AL = 1</b>	<b>AV = 25 - AL = 1</b>	<b>AV = 125 - AL = 1</b>		
<b>AV = 10 - AL = 1</b>	<b>AV = 30 - AL = 1</b>	<b>AV = 150 - AL = 1</b>		
	<b>AV = 40 - AL = 1</b>	<b>AV = 200 - AL = 1</b>		
	<b>AV = 50 - AL = 1</b>	<b>AV = 250 - AL = 1</b>		



The input shaft [AV] *fast* always shown on the bottom in the dimensional drawings is decisive for determining the reduction ratio.

When ordering, please always specify the value for the input shaft [AV] *fast* (the other shafts follow clockwise).

# Datasheet

## Shaft coupling

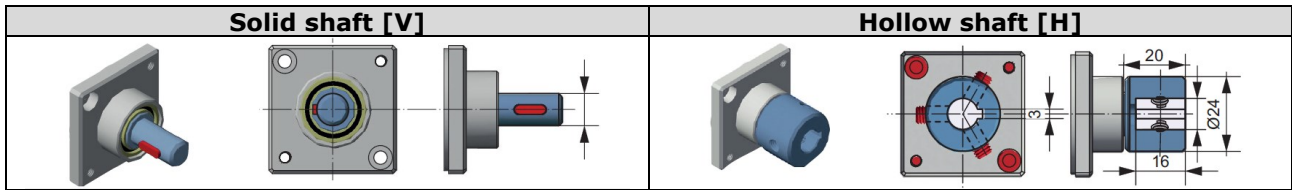

All dimensions in mm.

Solid shaft [V]	Hollow shaft [H]
V(Ø06x16 CH2)	H(Ø06x16 CH2)
V(Ø08x16 CH2)	H(Ø08x16 CH2)
V(Ø10x20 CH3) standard	H(Ø10x16 CH3)
V(Ø10x25 CH3)	H(Ø12x16 CH4)
V(Ø12x20 CH4)	H(Ø14x16 CH4)
V(Ø14x20 CH5)	

Available sizes (mm).



Shaft length: Solid shaft: 16 mm, 20 mm (standard) and 25 mm  
Hollow shaft: construction depth 20 mm, effective length 16 mm (standard)

Width of keyway (acc. to DIN 6885-1): CH2 = 2 mm, CH3 = 3 mm, CH4 = 4 mm, CH5 = 5 mm

## Shaft coupling hexagonal

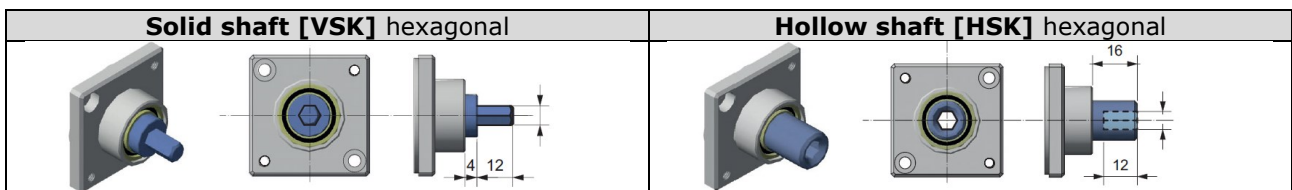

All dimensions in mm.

Solid shaft [VSK] hexagonal	Hollow shaft [HSK] hexagonal
VSK(Ø6,35x12)	HSK(Ø6,35x12)

Available sizes (mm).



Shaft length: Solid shaft (hexagonal): construction depth 16 mm, effective length 12 mm (standard)  
Hollow shaft (hexagonal): construction depth 16 mm, effective length 12 mm (standard)

## Shaft coupling Right-angle gear

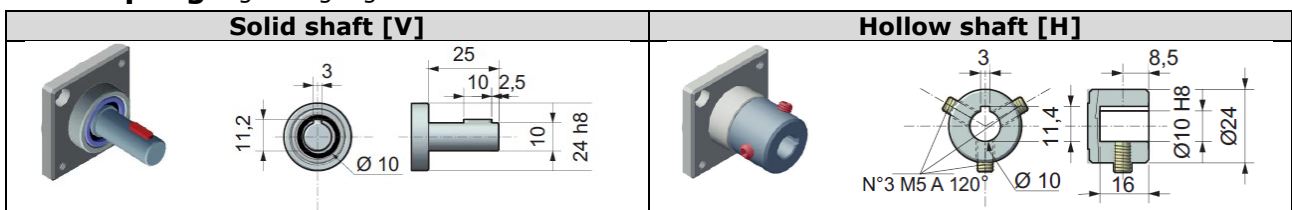

All dimensions in mm.

# Datasheet

## Ordering example

**Type** **RDE405** - **A** - **3/1S** - **V10** - **V-V** - **UI**

### Version

- A** = with 2 shafts
- B** = with 3 shafts
- C** = with 3 shafts (with opposite rotation)
- D** = with 3 shafts,  
(2 through hollow shafts)

### Ratio<sup>1)</sup>

- 3/1S** = 3 - 4 - 5 - 10 (1-stage)
- 15/2S** = 15 - 20 - 25 - 30 - 40 - 50 (2-stage)
- 125/3S** = 75 - 100 - 125 - 150 - 200 - 250 (3-stage)

### Input shaft [AV] *fast*

- V10** = V (Solid shaft), Ø... in mm; V06, V08, **V10**, V12, V14  
V(Ø10x20) mm (standard),  
V(Ø10x25) mm (optional, available on request)
- = H (Hollow shaft), Ø... in mm; H06, H08, H10, H12, H14  
H(Ø10x16) mm (standard)

### Output shaft [AL] *slow*

- V-V** = Solid shaft-Solid shaft
- = **V** (Solid shaft); **V**(Ø10x25) mm (standard)
- = H (Hollow shaft), Ø... in mm; H06, H08, H10, H12, H14  
H(Ø10x16) mm (standard)

### Use

- UI** = intermittent
- UC** = continuous

1) Value for the input shaft [AV] *fast* (the other shafts follow clockwise).



Other versions that cannot be generated from the order code may be available on request as special version.

Manufacturer: **FIAMA**  
since 1913



# Datasheet

## Reducer selection data



Ensure that the torque applied to the input does not generate an output greater than the allowable torque of the planetary gear itself.

### Continuous use (UC)

Determine the reduction ratio  $i$ :

$$i = \frac{m1}{m2}$$

$m1$  = motor revolutions

$m2$  = RDE output revolutions

Determine the output torque  $T_o$ :

$$T_o = i \times T_M \times R$$

$i$  = chosen ration

$T_M$  = max. motor / handwheel torque

$R$  = gearbox efficiency

### Intermittent use (UI)

Determine the reduction ratio  $i$ :

$$i = \frac{m1}{m2}$$

$m1$  = motor revolutions

$m2$  = RDE output revolutions

Determine the number of starts / hour  $A_0$ :

$$A_0 = \frac{3600}{TCS}$$

3600 = number of starts / hour

TCS = cycle time in seconds

### Thermal power verification (PT)

Verify thermal power  $PT$ :

$$PT = \frac{M1}{M2}$$

$M1$  = max. torque motor/handle

$M2$  = motor speed in rpm

# Datasheet

Glossary	
AL	output shaft <i>slow</i>
AV	input shaft <i>fast</i>
AO	number of starts
F	hollow shaft <i>female</i>
FA	axial load
FR	radial load
fs	service factor
fu	use factor
i	reduction ratio
M	solid shaft <i>male</i>
m1	motor revolutions
m2	reducer output revolutions
N	Newton
Nm	Newton meter
Pn	power
PT	Thermal power
R	efficiency
rpm	revolutions per minute
T	transmissible torque
TA	applied torque
TI	input torque
TM	maximum torque
TO	output torque
TON	nominal output torque
TR	recommended torque
TCS	cycle time in seconds
UC	continuous use
UI	intermittent use

## Fields of application

Planetary reducers or the combination of 90° right-angle gears with planetary reducers, are used in a wide variety of industries and systems:

- handling machines
- packaging machine
- food delivery
- drink delivery
- machine tools
- woodworking machines
- transfer lines
- printing machines
- wrapping machine
- manipulators
- linear guides
- automation
- robotics
- logistics
- metalworking machines

## Areas of application

Packaging, food, pharmaceutical, plastic, wood, sheet metal, glass, winding, construction road machines, also on traditional machines and special applications in metal construction, lifting technology, conveyor technology, linear technology, special plant engineering, etc.