

Datasheet



With Mitsubishi / Analog sin/cos (1 Vpp)-Interface

Basic features

- The AHP2L sensor is multifunctional and a particularly powerful, absolute position measuring system
- Particularly suitable for applications in mechanical engineering and automation technology where high accuracy of position and end position is required in real-time
- For monitoring linear and rotary movements
- Non-contact and therefore wear-free measurement
- Measuring range up to 16 m, repeatability $\leq 1 \mu\text{m}$
- Automatic recognition of the sensor and its settings, even after loss of operating voltage and restarting the system
- High reliability due to continuous plausibility check
- Status LED and diagnostic functions for reliable operation and accelerated maintenance
- Space-saving, compact design



Output/Interface

Clock	RS422 Differential signal (half-duplex)
Differential signals	yes
Real-time signals	analog sin/cos
Error signal	yes
Preset	configurable via hardware PIN or software tool
Interface	Mitsubishi Serial Interface, analog sin/cos (1 Vpp)
Interface coding	Binary
Signal sequence	A before B = rising
Counting direction	rising

Display/Operation

Function indicator	LED green LED yellow LED red
--------------------	------------------------------------

Datasheet

Electrical data

Operating voltage U_b	4.75...5.25 VDC / 10...28 VDC
Switch-on delay max.	1000 ms
Hysteresis H max.	2 μ m
Power consumption	≤ 1.5 W (no load)
Periods	2 mm
Voltage-proof up to (GND to housing)	500 VDC
Current consumption max. at 24 VDC	70 mA
Current consumption max. at 5 VDC	220 mA
Overvoltage protection	no

Electrical connection

Connection	Connector, M12x1 plug, 12-pin
Connection version	axial
Polarity reversal protected	no

Functional safety

MTTF (40 °C)	90 a
--------------	------



The MTTF value given does not represent any binding quality and/or service life commitments. They are merely empirical values without binding character. These values do not extend the limitation period for claims based on defects or influence it in any other way. For further information on MTTF, see MTTF certificate.

Detection range/measuring range

Resolution	2 μ m
Interpolation factor	1000
Read distance	0.01...0.8 mm
Non-linearity of sensor head, max.	± 2 μ m
Measuring range	48 m
Optimal read distance	0.4 mm
Traverse speed max., absolute interface	10 m/s
Traverse speed max., incremental interface	10 m/s
Repeat accuracy	≤ 1 μ m

Material

Housing material	Die-cast zinc, nickel plated, Chrome-plated
Housing material, surface protection	nickel plated Chrome-plated

Mechanical data

Dimension	16 x 18.5 x 80.3 mm
Mounting	Through-hole 4.3 mm
Diameter min.	243 mm
Weight	78 g (without cable)
Pitch max.	$\pm 0.5^\circ$
Pole width	2 mm
Roll max.	$\pm 0.5^\circ$
Lateral offset (Y)	± 0.5 mm
Tangential offset (X) max.	± 0.5 mm
Procedure direction	Lengthwise to magnetic scale
Yaw max.	$\pm 0.2^\circ$

Datasheet

Environmental conditions

Radiation	(EN 55016-2-3)	Industrial areas
Continuous shock	(EN 60068-2-27)	150 g, 2 ms
Shock	(EN60068-2-27)	100 g, 6 ms
Vibration	(EN 60068-2-6)	20 g, 10...2000 Hz
Noise	(EN600068-2-64)	20 g, 5...2000 Hz
ESD	(EN61000-4-2)	Severity Level 4
RFI	(EN 61000-4-3)	Severity Level 3
Burst	(EN61000-4-4)	Severity Level 3
Surge	(EN 61000-4-5)	Severity Level 2
High-frequency fields	(EN 61000-4-6)	Severity Level 3
Magnetic fields	(EN 61000-4-8)	Severity Level 5
External magnetic fields max., in operation		<1 mT (no effect)
Altitude max.		2000 m (above sea level)
Storage temperature		-25...85 °C
Relative humidity		≤ 90%, non-condensing
IP rating (connector)		IP67
Temperature coefficient, overall system		10.5 ppm/K
Ambient temperature		-20...70 °C

Approval/Conformity

Approval/Conformity	CE, cURus, EAC, WEEE
---------------------	----------------------

Dimensions

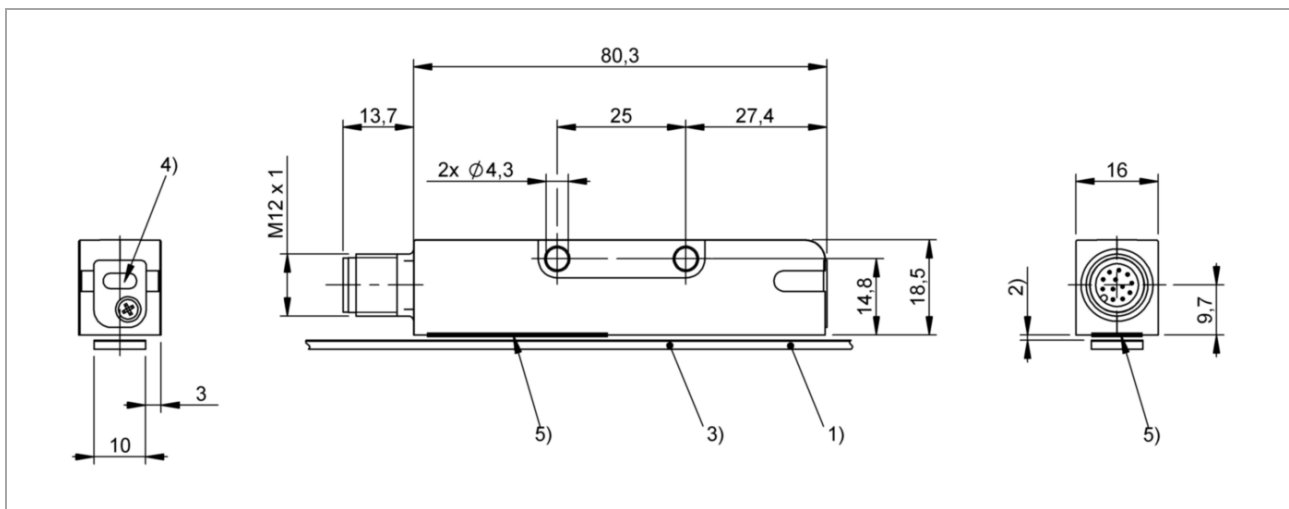

1) not included in scope of delivery, 2) distance to magnetic scale, 3) magnetic scale, 4) LED function indicator, 5) active measurement surface

Pin assignment

AHP2L - Pin assignment Connector M12 (view Pin side); Connection is performed via a 12-wire cable

PIN	Signal
1	+B (+Cos)
2	-B (-Cos)
3	+TxD/RxD
4	-TxD/RxD
5	NC
6	NC

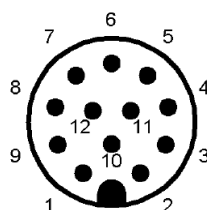

PIN	Signal
7	GND
8	VDC
9	-A (-Sin)
10	+A (+Sin)
11	PRESET
12	NC
SCH	Shield

Datasheet

Ordering example

Type **AHP2L** - **1** - **M** - **GS** - **24** - **O** - **0,94** - **CO** - **528**

Resolution

0,98 = 0,9765625 µm
1 = 1 µm
2 = 2 µm
5 = 5 µm
10 = 10 µm

Interface

M = Mitsubishi Serial Interface

Coding

GS = Gray rising
GF = Gray falling
BS = binary rising
BF = binary falling

Data format

24; 25; 26; 32 Bit

Incremental real-time signal

O = no real-time signal
VSS = Analog real-time signal sin/cos (1 Vpp)

min. Edge distance

0,11 / 0,26 / 0,42 / **0,94** / 1,8 / 3,5 / 7 / 14 / 21 µs

Electrical connection

CO = M12 connector (socket) 12-pin)

Operating voltage

528 = 5 VDC, 10-28 VDC

Accessories

Magnetic scale M02-A:

1 m length: #15620

24 m (roll): #26224

Magnetic scale can be supplied assembled in any length (up to 48 m in one piece) according to customer's specification.

Cover tape DB01:

1 m length: #16501

Cover tape can be supplied assembled in any length to customer's specification (up to 48 m in one piece).

Connector/cable:

5 m cable with M12 connector (socket) 12-pin: #31605

10 m cable with M12 connector (socket) 12-pin: #31610

Without prior notice, the products may be subject to modifications that the Manufacturer reserves to introduce as deemed necessary for their improvement.