



EXAG –PROFIsafe via Profinet Removable End Cap (SIL2)

- Shaft Encoder – Ø78 mm
- Shaft: Ø10 mm, Ø12 mm
- PROFIsafe protocol with PROFINET interface
- Resolution up to 13 bits
- Removable End Cap for on-site modification
- ATEX, IECEx, EAC, North American Class I, Div. 2, Ex db IIC.

Electrical Specifications

Code:	Absolute - Binary
Interface:	Profinet
Profile	Profidrive Profile 4.x, Encoder Profile 4.x
Resolution:	Max. 12 bit (4096) revolutions Max. 13 bit (8192) steps per rev.
Device Addressing:	Programmable IP address and Network parameters
Transmission Rate:	10/100 Mbit/s
Supply Voltage:	9 to 30 VDC
Current Consumption:	Max. 300 mA
Power Consumption:	Max. 2.5 W
Accuracy (INL):	±0.2% (with reference to one revolution)
MTTF:	162 years (EN ISO 13849-1)
Electrical Protection:	Reverse polarity and over-voltage-peak protection
Acc. to EN 61508	SIL2 PFH = 9.889 x 10 ⁻⁸ [1/h] SFF = 92,2% HFT = 0
Noise Immunity:	EN61000-6-2
Emitted Interference:	EN 61000-6-4

Mechanical Specifications

Material:	Housing: Aluminum or Stainless Steel Cap: Aluminum or Stainless Steel Shaft: Stainless Steel
Weight:	Aluminum: ~ 1600 gr (56,44 oz) Stainless Steel: ~ 3100 gr (109,35 oz)
Bearing Life:	> 1,9 x 10 ¹⁰ revolutions at rated load
Shaft Speed:	6.000 rpm (max.) IP 64 3.000 rpm (max.) IP 65, IP 66, IP 67
Starting Torque:	≤ 0,01 Nm at 25° C (no seal) ≤ 0,03 Nm at 25° C (with seal)
Rotor Mass Moment of Inertia:	42 gcm ² (5,95 x 10 ⁻⁴ oz-in-sec ²)
Shaft Loads:	Axial: 60 N (13,50 lbs) max. Radial: 80 N (17,98 lbs) max.

Environmental Specifications

Operating Temp.:	-40° to +70° C
Storage Temp.:	-40° to +70° C
Shock:	100g @ 11 ms
Vibration:	10g @ 10-2000 Hz
Bump:	10g @ 16 ms (1000 x 3 axis)
Humidity:	98 % RH without condensation
Enclosure Rating:	IP 64 / Nema 4 (approx.) IP 65 / Nema 5 (approx.) IP 66 / Nema 6 (approx.) IP 67 / Nema 6 (approx.) IP 68 (1hour/1 meter) / Nema 6P (approx.)

Certifications

ATEX:	Certificate No.: ITS09ATEX16867X II 2 G Ex db IIC T5 Gb, II 2 D Ex tb IIIC T100°C Db -40°C ≤ Ta ≤ +70°C
IECEX:	Certificate No.: IECEX ITS 10.0016X Ex db IIC T5 Gb, Ex tb IIIC T100°C Db -40°C ≤ Ta ≤ +70°C
North America:	Certificate No: LR1192-5 Class I Division 2, Groups ABCD T5, Class II Division 2 Groups FG, Class I Zone 1 AEx db IIC T5 Gb, Ex db IIC T5 Gb, Zone 21 AEx tb IIIC T100°C Db, Ex tb IIIC T100°C Db, Tamb= -40 °C to +70 °C
EAC Ex:	HAHIO «ИЦБЭ» No. EAЭC RU C-DK.AA87.B.00266/19 1Ex db IIC T5 Gb X, Ex tb IIIC T100°C Db X -40°C < T.amb < +70°C

Interface

The User Manual for Profinet interface and GSD file are referring to firmware of [TRT/S3!](#)

You can find the User manual and GSD file under the product - EXAG SIL2.

The Profinet interface supports real time classes 1 and 3, i.e. Real Time (RT) and Isochronous Real Time (IRT) plus the requirements of conformance class C. To achieve the SIL2 level, the encoder contains additional internal monitoring mechanisms as well as safe communication via PROFIsafe. The PROFIsafe protocol is implemented according to the PROFIsafe Profile for Safety Technologie version 2.4 (PNO Order No. 3.192). Setting the address, baud rate or terminating resistances is not necessary.

A name, which is stored in the absolute encoder's non-volatile memory, is assigned via the PROFINET controller to address the device.

Following encoder parameters can be programmed directly via the PROFINET.

Parameter	Value range	Comment
Scalling	off / on	
Code path	CW/CCW	CW (clockwise): ascending values on rotation clockwise CCW (counter clockwise): descending values on rotation clockwise (viewed looking at the shaft)
Resolution [steps/360°]	1 ... 4096(8192) 4096(with coding W)	The parameter "resolution" is used to program the desired number of steps per revolution. Each value between 1 and the physical resolution per revolution can be programmed
Total number of steps [steps]	1 ... 16,777,216	This parameter is used to program the desired number of measuring units over the total measuring range. This value may not exceed the total physical resolution of the absolute rotary encoder.
Reference Value	0 ... total number of steps -1	For adaptation to the application, the position value can be set to any value within the measuring range. Once programmed, a reference value can be set via bit 0 in the control word (output data).
Gate time	10 ... 1000 ms	Time basis for speed registration

Output Terminations

		Terminal connections
Position	Ports	Terminal (from left)
1	PORT 1	RX1 - (blue)
2		RX1 + (white)
3		TX1 - (orange)
4		TX1+ (yellow)
5	PORT 2	RX2 - (blue)
6		RX2 + (white)
7		TX2 - (orange)
8		TX2 + (yellow)
9	Power Supply	+UB (+24 VDC)
10		- UB (0 VDC)

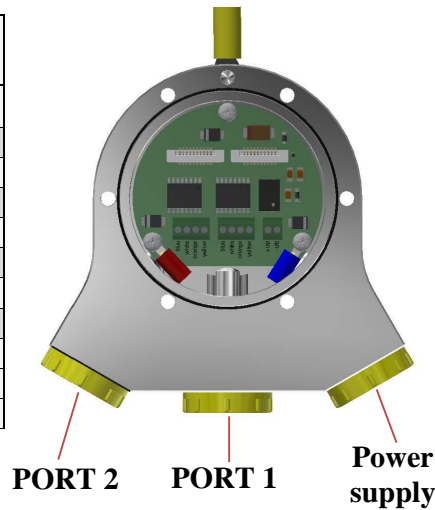

Internal earth connection

Red cable shoe is 22-16 AWG.
La connexion à la terre interne (Borne rouge) est en 22-16 AWG.
 Blue* cable shoe is 16-14 AWG.
La connexion à la terre interne (Borne rouge) est en 16-14 AWG.

*) connect shield from Port2 & Power supply cable.

External earth connection

(yellow cable shoe) is 12-10 AWG.
La connexion de terre externe (Borne jaune) est en 12-10 AWG.

Terminal block : wire conductor size
 AWG 30-18, 0.0509 mm² – 0,823 mm².
La taille de fil nominale est AWG 30-18, 0.0509 mm² – 0,823 mm²

Face Mounts

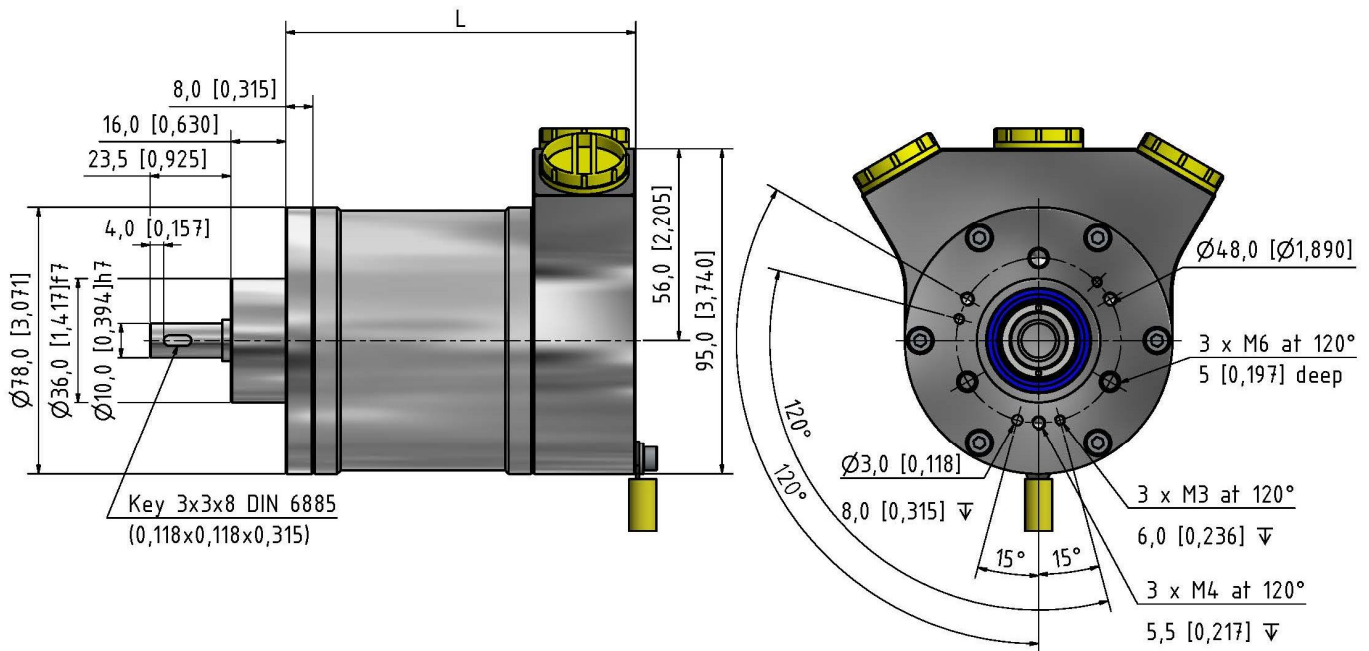

Face Mount C
Clamping Flange

mm [inches]

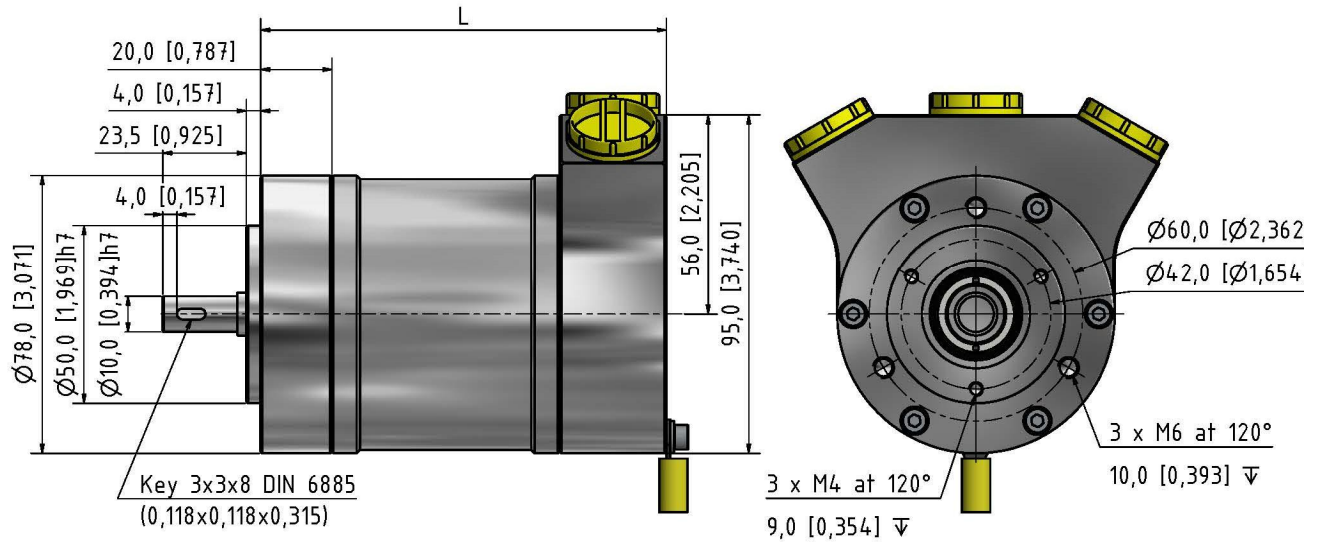

Face Mount S
Servo Flange

mm [inches]

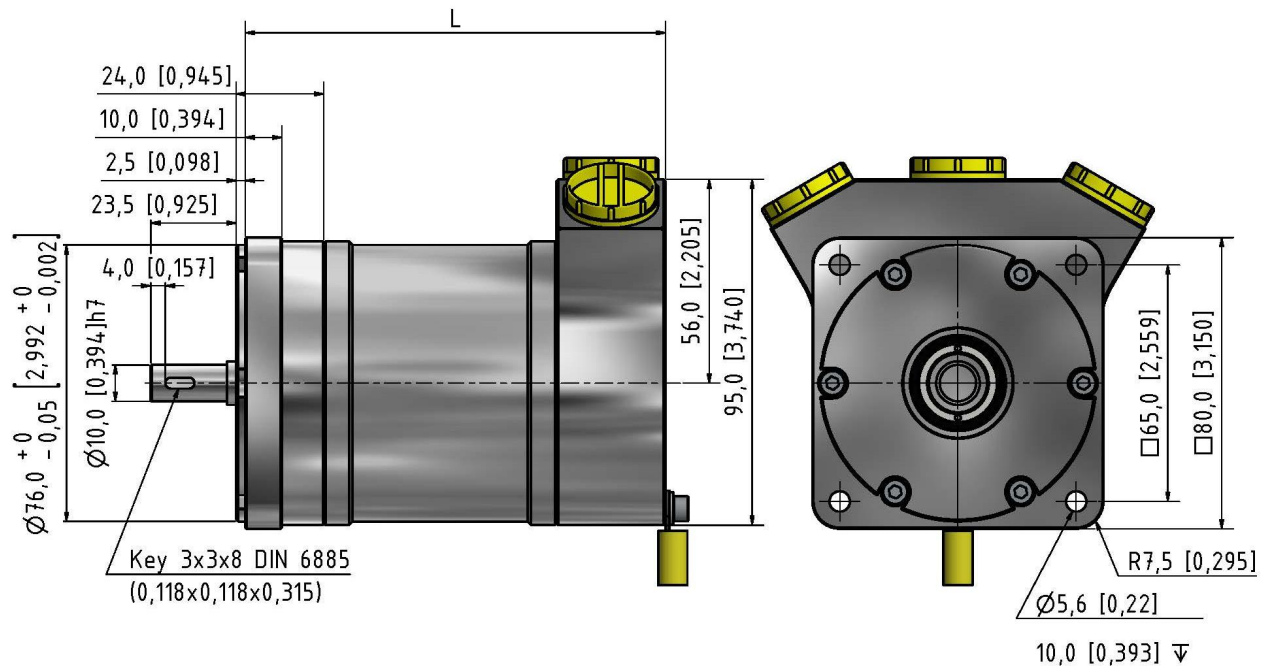

Face Mount Q
Square Flange
SA option only

mm [inches]

End Caps with Cable Outlets

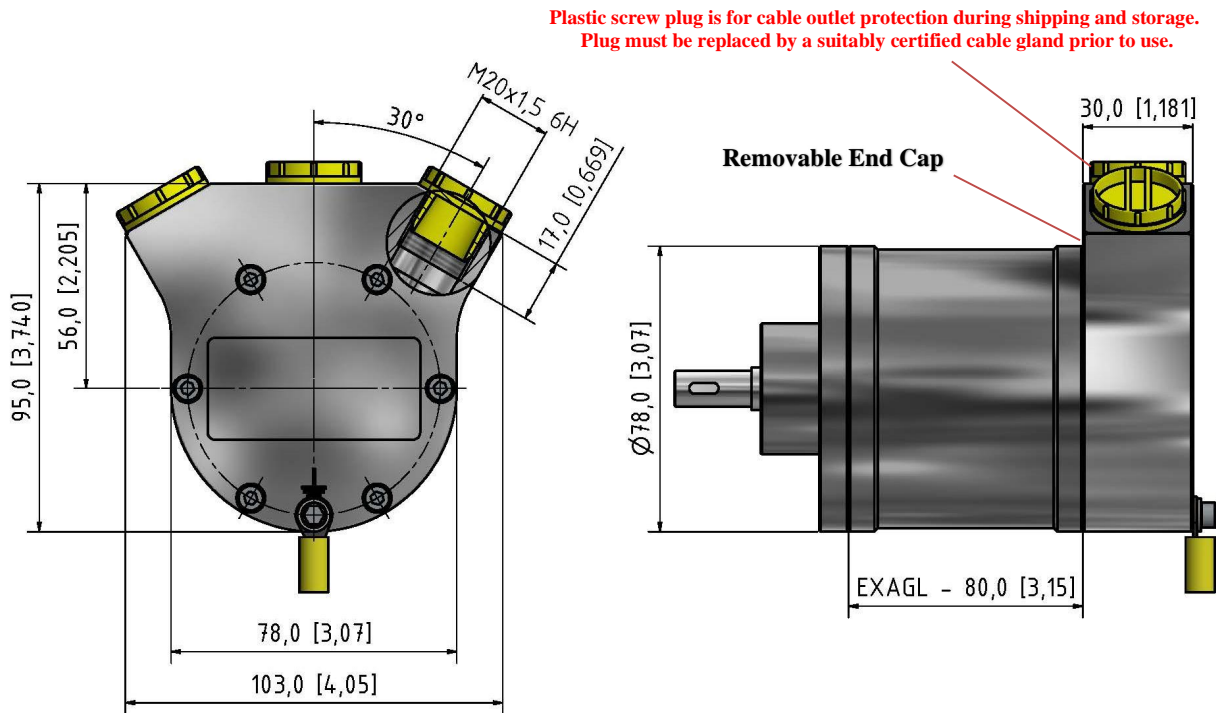

Side Standard End Cap (FE)

mm [inches]

Encoder Length

Housing L (Table 1)

(80 mm)

Total Encoder Length

End Cap	Face Mount		
	Clamping Flange C	Servo Flange S	Square Flange Q
FE	118 mm (4,645 in)	130 mm (5,118 in)	131,5 mm (5,177 in)

End Cap + Face Mount + 80 mm = Total Encoder Length

Ordering Code

Example: EXAGL - TRT - 13 - R - 12 - S3 - KP - A - SA - 08 - 66 - 00 - FE - C - 00

EXAG	L	-	TRT	-		-		-		-	S3	-	KP	-	A	-		-	08	-		-	00	-	FE	-		-	00
1			2		3		4		5		6		7		8		9		10		11		12		13				

1. Housing

80 mm length L

See Table 1

4. Output code

Binary* R

Binary* W

Binary*** D

* position value divided into two words.

** position value divided into two words,

1. word multiturn data, 2. word single turn data, resolution not adjustable.

*** position as double word.

7. Composition

Aluminum AL

Stainless Steel* VA

Stainless Steel** SA

* AISI 303

** AISI 316

2. Interface

Version TRT

5. Revolutions

Single Turn 00

Multiturn 12 bits (4096) 12

3. Resolution

12 bits (4096) (0.09°) 12

13 bits (8192) (0.04°) 13

6. Profile

PROFIsafe, SIL2 certified S3

8. Shaft (diameter x length)

10 mm x 20 mm key 3x3x8 DIN 6885 08

9. IP Rating

IP 64 64

IP 65 65

IP 66 66

IP 67 67

IP 68* 68

*1 meter/1 hour

10. Cable

No cable 00

11. Cable Outlets

Side Triple 3 outlets FE

12. Flange

Clamping flange C

Synchro flange S

Square SA option only Q

13. Accessory

No accessory 00