



## Incremental miniature magnetic sensor with square-wave output signal



### General Characteristics

- Magnetic sensor for linear and angular contactless reading.
- Very small size, to allow installation in narrow spaces.
- Housing of the magnetic sensor made of die-cast metallic material.
- Resolutions up to 0.2  $\mu\text{m}$ .
- Status indication through LED RGBW.
- Flexible cable allows axial or radial connection of the sensor.
- Easy and fast mounting of the entire measuring system, with wide alignment tolerances.
- Option: cleaning wipers to remove dirt deposits from the magnetic scale, ensuring the correct functioning of the measuring system.
- To be used with incremental coded magnetic scale PM2, composed by a magnetized plastic with barium strontium particles, with pole pitch 2+2 mm. The magnetized plastic is supported by a stainless steel tape, already provided with an adhesive tape, for an easy application on the machine.

### Technical Characteristics

Pole pitch	2+2 mm
Reference indexes	<b>C</b> = constant step (every 4 mm) <b>R</b> = positioned on the magnetic scale
Resolution [ $\mu\text{m}$ ]	100   50   10   5   1   0.5   0.2
Accuracy grade	$\pm 8 \mu\text{m}$ <sup>1)</sup>
Interpolation error (SDE)	$\pm 1 \mu\text{m}$ <sup>2)</sup>
Unidirectional repeatability	$\pm 0.5 \mu\text{m}$ <sup>2)</sup>
Hysteresis	$2 \mu\text{m}$ <sup>2)</sup>
A, B and I <sub>0</sub> output signals	Line Driver / Push-Pull
Vibration resistance (EN 60068-2-6)	300 m/s <sup>2</sup> [55 ... 2000 Hz]
Shock resistance (EN 60068-2-27)	1000 m/s <sup>2</sup> [11 ms]
Protection class (EN 60529)	IP 67
Operating temperature	-20 °C ... 75 °C
Storage temperature	-40 °C ... 80 °C
Relative humidity	100%
Power supply	5 to 24 VDC $\pm 10\%$ <sup>3)</sup>
Current consumption without load	40 mA <sub>MAX</sub>
Current consumption with load	100 mA <sub>MAX</sub> (with 5 V and R = 120 $\Omega$ ) 80 mA <sub>MAX</sub> (with 24 V and R = 1.2 k $\Omega$ )
Electrical connections	see related table
Electrical protections	inversion of polarity and short circuits
Weight	20 g

<sup>1)</sup> The declared accuracy grade of  $\pm X \mu\text{m}$  is referred to a measuring length of 1 m.

<sup>2)</sup> The error declared is subject to the respect of the alignment tolerances.

<sup>3)</sup> **Voltages higher than 27 VDC will damage the sensor.**

# Datasheet

## Mechanical Characteristics

- Housing of the magnetic sensor made of die-cast metallic material.
- Possibility to fix the magnetic sensor with M3 screws or with through M2.5 screws.
- Wide alignment tolerances.

## Electrical Characteristics

- Reading through positioning sensor based on magneto resistance, with AMR effect (Magnetic Anisotropy).
- High signal stability.
- Electrical protection against inversion of power supply polarity and short circuits on output port.
- For applications where the maximum speed exceeds 1 m/s, it is necessary to use a cable suitable for continuous movements.

## Wiring and Pin Assignment (assignment according to DIN 47100)

### 8-wire connecting cable

Incremental magnetic sensor MIP2 is supplied with an 8-wire shielded cable,  $\varnothing = 4.4$  mm, PUR external sheath, with low friction coefficient and oil-resistant.

Conductors section:

- power supply: 0.135 mm<sup>2</sup>
- signals: 0.08 mm<sup>2</sup>



**The cable's bending radius should not be lower than 50 mm.**

Pin diagram **connector M12 plug**, 8-pin, A-coded, view plug side, connected to the connecting cable of the magnetic sensor.

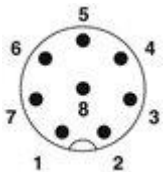

Line Diver	Push-Pull	PIN	Conductor colour
$I_0$	$I_0$	1	brown
$\overline{I_0}$	NC	2	yellow
B	A	3	white
$\overline{B}$	NC	4	light-blue
$\overline{A}$	NC	5	orange
A	B	6	green
0V	0V	7	blue
+V	+V	8	red
SCH	SCH		shield

# Datasheet

## 8-wire extension cable Type VLK-8 (optional)

Pin diagram connector M12 plug, 8-pin, A-coded, view plug side, connected to an extension cable (e.g. 0,3 m, 5 m, or 30 m).

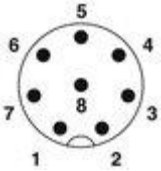

Signal	PIN	Conductor Colour
$I_0$	1	white
$\overline{I_0}$	2	brown
B	3	green
$\overline{B}$	4	yellow
$\overline{A}$	5	grey
A	6	pink
0V	7	blue
+V	8	red
SCH		shield

Pin diagram connector M12 socket, 8-pin, A-coded, view socket side, connected to an extension cable (e.g. 0,3 m, 5 m, or 30 m).

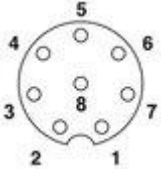

Signal	PIN	Conductor Colour
$I_0$	1	white
$\overline{I_0}$	2	brown
B	3	green
$\overline{B}$	4	yellow
$\overline{A}$	5	grey
A	6	pink
0V	7	blue
+V	8	red
SCH		shield

# Datasheet

## Output Signals

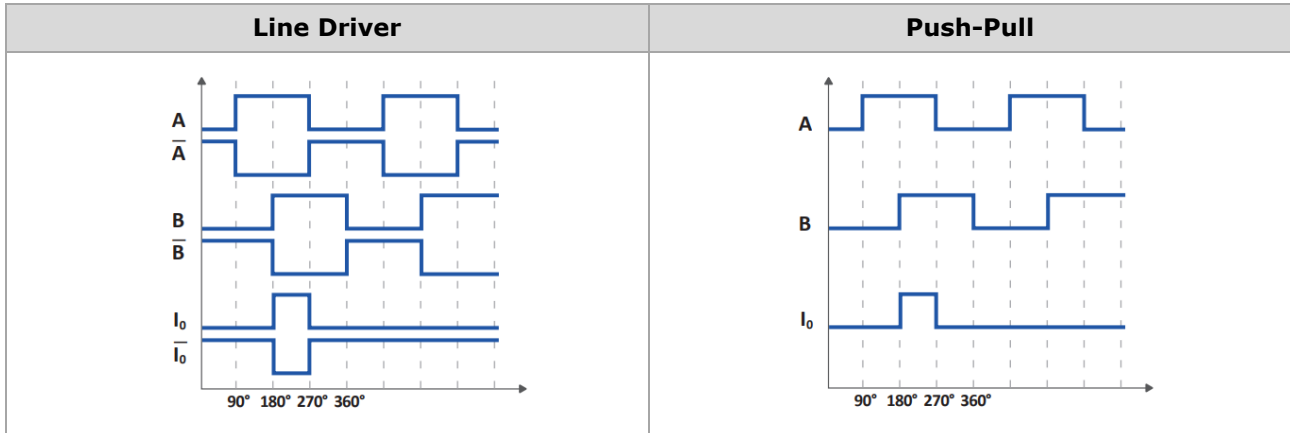

## Maximum Speed

Resolution ( $\mu\text{m}$ )	100	50	10	5	1	0.5	0.2	Min. edge separation ( $\mu\text{s}$ )
Standard speed (m/s)	47	47	34	17	3.4	1.7	0.7	0.24
High speed (m/s)	-	-	47	34	7	3.4	1.4	0.12

## Dimensions and drilling diagram

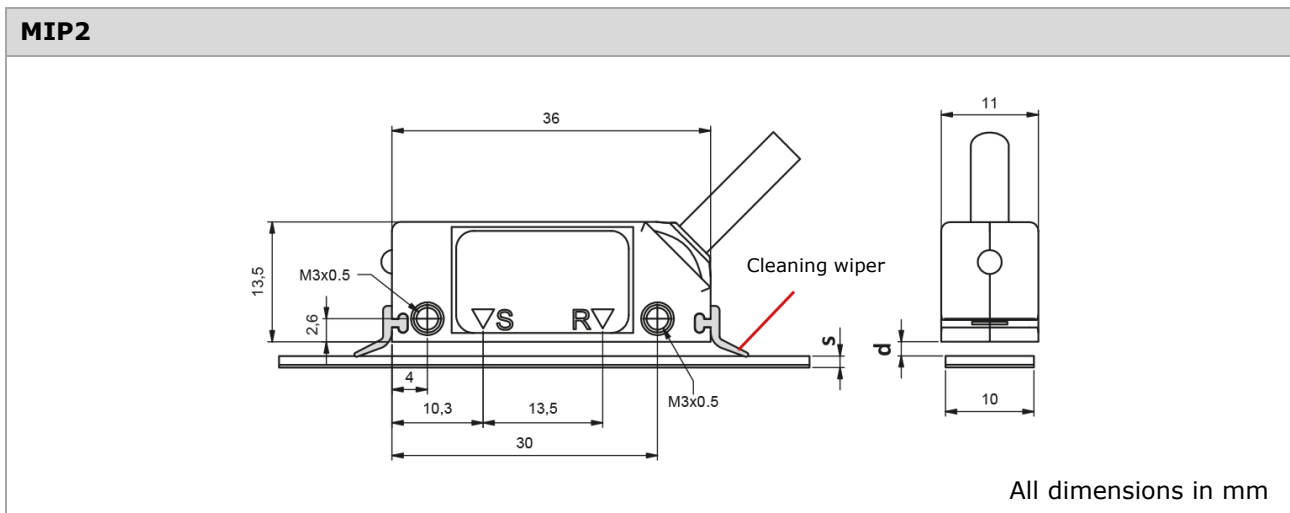

**s (mm)** = thickness magnetic scale

<b>PM2<sup>1)</sup></b>	thickness without double-sided adhesive tape	1.35 -0.05 +0.075
	thickness with double-sided adhesive tape	1.55 ±0.1
<b>PM2+ DB01<sup>2)</sup></b>	thickness with double-sided adhesive tape and cover tape DB01	1.70 ±0.1
<b>PM2+ DB22<sup>3)</sup></b>	thickness with double-sided adhesive tape and cover tape DB22	1.70 ±0.1

<b>d (mm)</b> = distance to be maintained between sensor and surface		
<b>PM2<sup>1)</sup></b>	distance to be maintained between sensor and surface of the magnetic scale (without cover tape)	0.1 ... 0.3
<b>PM2+ DB01<sup>2)</sup></b>	distance to be maintained between sensor and surface of the cover tape/support	0.1 ... 0.20
<b>PM2+ DB22<sup>3)</sup></b>		0.1 ... 0.15

- 1) Incremental magnetic scale PM2, composed by a magnetized plastic with barium strontium particles, with pole pitch 2+2 mm. The magnetized plastic is supported by a stainless steel tape, already provided with an adhesive tape.
- 2) Non-magnetic stainless steel cover tape DB01 on which a double-sided adhesive tape is pre-mounted for a quick sticking and an easy fixing on the magnetic scale.
- 3) Non-magnetic stainless steel cover tape DB22 on which a double-sided adhesive tape is pre-mounted for a quick sticking and an easy fixing on the magnetic scale; only for mounting with profiled rail PS6.

### Alignment Tolerances

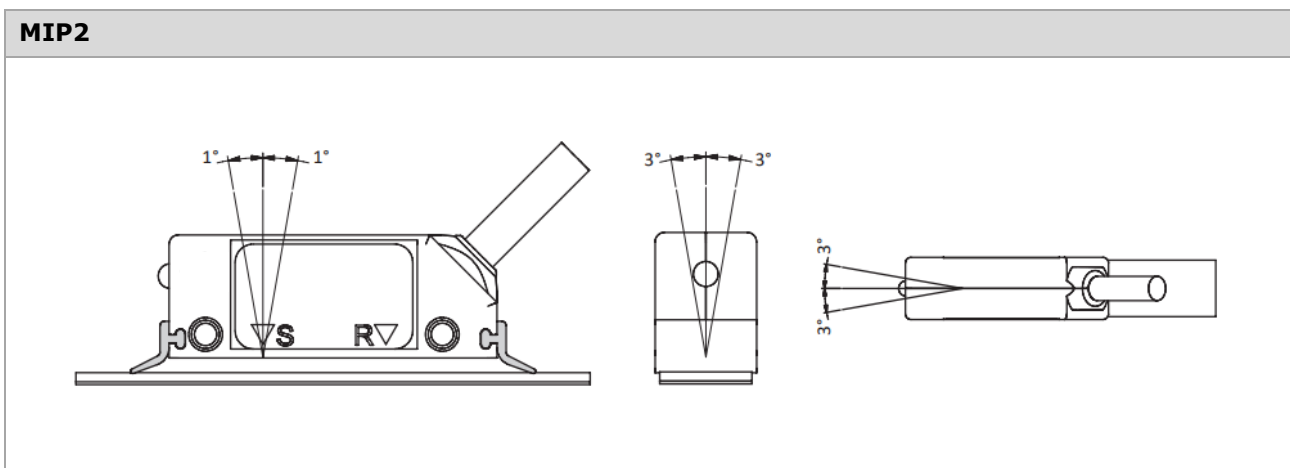

<b>MIP2 + PM2</b>	<b>a (mm)</b> = alignment tolerance
	<p><b>a = 1<sub>MAX</sub><sup>1)</sup></b>  <b>a = 0.5<sub>MAX</sub><sup>2)</sup></b></p> <p>Reference indexes:</p> <ol style="list-style-type: none"> <li>1) <b>C</b> = constant step (every 4 mm)</li> <li>2) <b>R</b> = with fixed reference point positioned on the magnetic scale</li> </ol>

### NOTICE

- Avoid the direct contact with magnetized objects or tools that could damage the surface.
- **Do not touch** the contacts of the cable's connector to avoid electrostatic discharges (ESD) on the device.

# Datasheet

The following graphs show tests carried out in a metrological room under controlled climatic conditions:  
T= 20 °C ± 0.1 °C and R.H.= 45% ... 55%.

The reference system for the comparison of position measurements is interferometric with 1 nm resolution and equipped with an environmental compensation device. The sensor is installed according to the recommended mechanical configuration at a distance of 0.3 mm from the magnetic scale.

## Accuracy and Interpolation

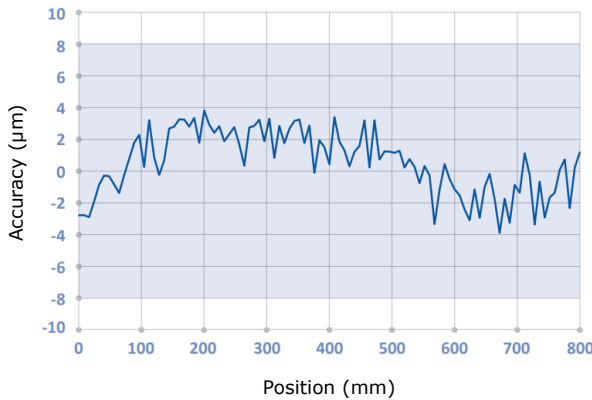
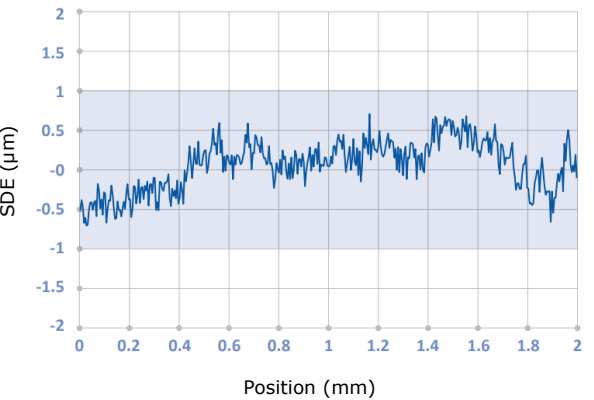
Accuracy	Interpolation - SDE
	
<p>Accuracy graph: deviation between the value measured by the sensor and the value measured by the reference system.</p>	<p>SDE (sub-division error) graph: accuracy of the interpolation device within the single pole pitch.</p>

## Repeatability

Repeatability graph obtained by carrying out the measurements several times in both directions of advancement.

- Unidirectional repeatability: measurement error detected without inverting the movement direction of the sensor.
- Hysteresis: difference in the measure due to the inversion of the sensor movement direction.

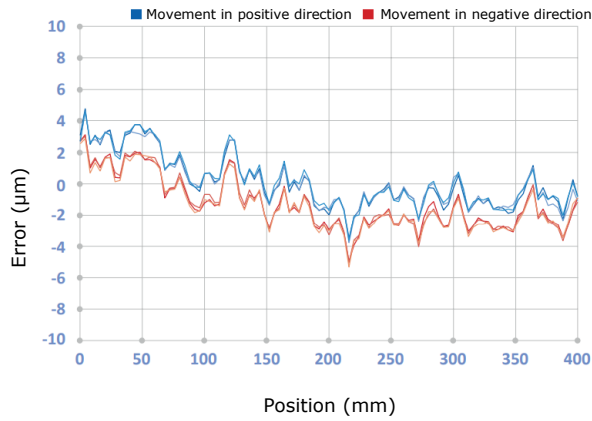
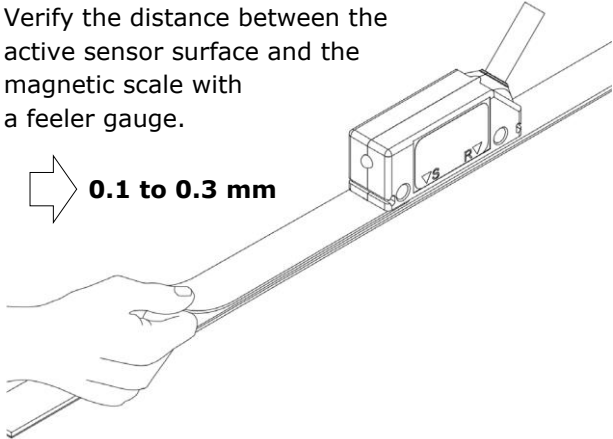
Repeatability	
	<p>Verify the distance between the active sensor surface and the magnetic scale with a feeler gauge.</p> 

# Datasheet

## Ordering Example Magnetic sensor

**Type** MIP2 - 1 - C - 524V - L - S - M02 - SC

### Pole pitch

**2** = 2+2 mm

### Resolution [ $\mu\text{m}$ ]

100 / 50 / 10 / 5 / **1** / 0.5 / 0.2

### Reference index

**C** = constant step (every 4 mm)

**R** = positioned on the magnetic scale

### Power supply

**524V** = 5 VDC ... 24 VDC

### Output signals

**L** = Line Driver

**Y** = Push-Pull

### Speed

**S** = standard

**H** = high

### Cable <sup>1)</sup>

**M01** = 1 m

**M02** = 2 m

**M03** = 3 m

### Connection

**SC** = without connector, open cable end

**Cxx** = progressive (e.g. C08 = connector M12 plug, 8-pin)

- <sup>1)</sup> Different cable lengths are available. As a standard, the sensor is supplied with a 2 m cable. Longer lengths are available, with the following limits:

$L_{\text{max}} = 10 \text{ m}$  sensor cable

$L_{\text{max}} = 50 \text{ m}$  2 m sensor cable + cable extension

Cable extensions need to have a section of at least  $0.5 \text{ mm}^2$  for power supply conductors.



### Accessories

Please order the magnetic scale, the corresponding cover tape, the profiled rail, and the extension cable separately. For ordering information, please refer to the corresponding data sheet. Cleaning wipers to remove dirt deposits from the magnetic scale (on request).

You can configure the enclosure according to your requirements from the technical information and enter it into the ordering code.

Variants that cannot be configured from the ordering example are available on request as a special version.

# Datasheet

## Ordering example Magnetic scale

**Type** PM2 - 30 - 1000 - O - DB01

**Pole pitch**

**2** = 2+2 mm

**Accuracy grade** (referred to a measuring length of 1 m)

**8** = 8 µm (max. 1000 mm)

**10** = 10 µm

**15** = 15 µm

**30** = 30 µm

**Measuring length** [mm]

The entered amount should be on each side 40 mm longer than the desired measuring length

**Reference point** [mm]

**O** = without

**SN50** = fix; specifying position from the right <sup>1)</sup>

**SA50** = periodically; specifying position from the right

**Cover tape**

**O** = without

**DB01** = for Magnetic scale PM1 and PM2

**DB22** = for Profiled rail PS5 and PS6

<sup>1)</sup> **Manual setting of a reference point on the magnetic scale**

On customer request, a specific reference point can be integrated at any position on the magnetic scale by targeted demagnetisation of the magnetic track. Please refer to the data sheet of the magnetic scale.

## Ordering example Profiled rail

**Type** PS1 - 1,0

**PS1** = Pole pitch > 5+5 mm

**PS5** = incl. cover tape DB22

**PS6** = incl. cover tape DB22

**SB**

**Measuring length** [m]

The entered amount should be on each side 40 mm longer than the desired measuring length

## Ordering example Cover tape

**Type** DB01 - 1,0

**DB01** = for Magnetic scale PM1 and PM2

**DB22** = for Profiled rail PS5 and PS6

**Measuring length** [m]

The entered amount should be on each side 40 mm longer than the desired measuring length

Without prior notice, the products may be subject to modifications that the Manufacturer reserves to introduce as deemed necessary for their improvement.